

DOCUMENT RESUME

ED 385 250

IR 017 272

AUTHOR Crannell, Philip A.
 TITLE Multimedia Centers: Concepts for the Future.
 INSTITUTION Gee & Jenson Engineer-Architects-Planners, Inc. West Palm Beach, FL.
 PUB DATE 10 May 95
 NOTE 89p.; Paper presented at the Florida Library Association Annual Conference and Exhibition (72nd, Fort Lauderdale, FL, May 9-12, 1995). Color figures may not reproduce well.
 PUB TYPE Guides - Non-Classroom Use (055)
 EDRS PRICE MF01/PC04 Plus Postage.
 DESCRIPTORS Access to Information; Facility Improvement; Futures (of Society); Information Technology; Library Equipment; *Library Facilities; *Library Planning; Library Services; *Multimedia Materials; *Telecommunications
 IDENTIFIERS Electrical Wiring; *Multimedia Technology; Raceways Distribution System; Structured Cabling System

ABSTRACT

Because of public demand for access to new media, librarians must be able to provide specialized systems and facilities. To support librarians in the planning and rethinking of new multimedia libraries, the firm of Gee & Jenson, which specializes in library design, created this guide. It provides an illustration of the possibilities and important issues to ensure multimedia service and flexibility. The topics discussed in section one include information equity; the virtual library; multimedia equipment; training; and library multimedia centers and functions. Section 2, "Critical Multimedia," covers support requirements such as power sources, communications systems, the data grid and hubs, and the telecommunications room. The third section, "Checklist and Worksheets," contains various aids designed to help organize the renovation and design process for multimedia facilities. Included in section 4, "Checklist," are: the steps needed for wiring a library for multimedia, lists important data access points in the library, and recommendations for information kiosks. "Cables and Raceways Design for Multimedia Libraries," section 5, is provided to assist librarians in planning for communications needs, and to assist a consultant in planning and designing a Structured Cabling System combined with a Raceways Distribution System (telecommunications and power grids). A glossary of related vocabulary is appended, and several figures and tables illustrate concepts. (MAS)

 * Reproductions supplied by EDRS are the best that can be made *
 * from the original document. *

EL 385 250

Florida Library Association

72nd Annual Conference and Exhibition 1995

U.S. DEPARTMENT OF EDUCATION
Office of Educational Research and Improvement
EDUCATIONAL RESOURCES INFORMATION CENTER (ERIC)

This document has been reproduced as received from the person or organization originating it.

Minor changes have been made to improve reproduction quality.

• Points of view or opinions stated in this document do not necessarily represent official OERI position or policy.

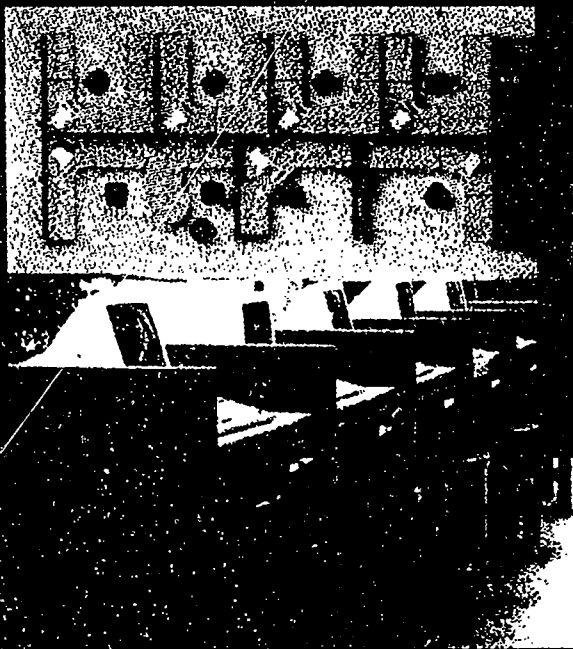

Multimedia Centers: Concepts for the Future

Gee & Jenson
Engineers-Architects-Planners, Inc.

IR 017272

"PERMISSION TO REPRODUCE THIS MATERIAL HAS BEEN GRANTED BY
Philip Crannell

TO THE EDUCATIONAL RESOURCES INFORMATION CENTER (ERIC)."

MULTIMEDIA CENTERS: CONCEPTS FOR THE FUTURE[©]

AS PRESENTED TO

THE

FLORIDA LIBRARY ASSOCIATION
72ND ANNUAL CONFERENCE
& EXHIBITION 1995

MAY 10, 1995

BY:

PHILIP A. CRANNELL, AIA
EXECUTIVE VICE PRESIDENT

Copyright © by Philip A. Crannell, AIA

*All rights reserved. No part of this book may be reproduced or transmitted in any form or by any means,
electronic or mechanical, including photocopying, recording, or by any information storage and retrieval system,
without prior written permission from the author. For information, contact Gee & Jenson EAP, Inc.*

MULTIMEDIA CENTERS: CONCEPTS FOR THE FUTURE®

TABLE OF CONTENTS

<u>Introduction</u>	
Commitment to Flexibility In Library Design	1
Information Equity	3
Library Facilities In Transition	3
1.0 The Virtual Library	4
1.1 Keeping Pace with Evolving Information Technology	4
1.2 Adapting Libraries For The Changes Ahead	5
1.3 Important New Features in a Multimedia Library	6
1.3.1 Equipment	6
1.3.2 Utilizations	6
1.3.3 Optimizing Multimedia Equipment and Its Utilization	6
1.4 New Spaces to Support Multimedia Operations	7
1.4.1 Training Center	7
1.4.2 Group Multimedia Production Room	7
1.4.3 Output Center	8
1.4.4 Multimedia Support Center	9
1.4.5 Multimedia Classification Room and Receiving Center	9
1.4.6 Archiving Center	10
1.5 Introducing New Multimedia Functions Into Libraries	10
1.6 Renovation Projects	11
1.7 New Construction	11
1.8 Flexibility Tools	12

1.8.1	Flexibility Enhancements	13
2.0	Critical Multimedia	14
2.1	Power Features	14
2.2	Communication Systems	14
2.3	The Importance of the Data Grid	15
2.3.1	Data Grid Hubs	16
2.3.2	Telecommunications Room	16
3.0	Checklist and Work Sheets	23
3.1	Important New Multimedia Areas in New Libraries	
3.2	How to Critique a Multimedia Design Proposal	23
3.2.1	Critiquing a New Design for a Media Center	
3.2.2	Multimedia Operations to Look For	25
3.2.3	Critiquing Existing Facilities as a Candidate for a Media Center	25
4.0	Checklist	37
4.1	Steps to Take to Wire Your Library for Multimedia	37
4.1.1	Programming Phase	37
4.1.2	Design Phase	38
4.1.3	Project Closeout Phase	39
4.1.4	Telecommunications Room Features	41
4.2	Characteristics of a Properly Wired Library	42
4.3	Important Data Access Points in Library	42
4.4	Information Kiosks	43
5.0	Cables and Raceways Design for Multimedia Libraries	44
5.1	What Kind of Cable Should You Use?	45

5.2	What are the Advantages of Using Fiber Optic Cables?	46
5.3	How Does Fiber Optic Cable Differ From Copper Cable?	46
5.4	What Is A Broadband System?	48
5.5	What Are The Advantages and Disadvantages of Using Broadband/Coax Cables?	51
5.6	What Are the Deciding Factors to Use Fiber Optic Cables vs. UTP?	51
5.7	What is the Most Economical Way to Wire the In-Building Backbone Subsystem?	53
5.8	Where Should the Telecommunications Room Be Located in the Facility?	53
5.9	What Size Telecommunications Room Will I Need?	53
5.10	What are the Conditions that Affect Cable Location Selection?	55
5.11	What Causes Interference or Static Noise?	55
5.12	What Can I Do To Minimize Voice/Data Signals Distortion and Failure?	56
5.13	Why Install Category Five Communications System?	57
5.14	What is Structured Cabling System?	58
5.15	System Architecture	59
5.16	System Configuration	61
5.17	Face-Plate Configuration	62
5.18	Space Requirements	62
5.19	System Infrastructure	65
5.20	In-Floor Distribution System	66
5.20.1	Under-Floor Duct System	66
5.20.2	Recessed Floor Boxes	66
5.21	Overhead Distribution System	67
5.22	Surface Mounted Raceways	67

5.23 The Do's and Don'ts of Cabling and Raceways 68

The Important of Conduit 70

Flexibility Enhancements - Data Grid Routing Recommendations 71

Related Vocabulary (Glossary) 72

INTRODUCTION -- COMMITMENT TO FLEXIBILITY IN LIBRARY DESIGN

There is tremendous potential for the various ways you can plan and prepare your library for the future. Preparation made today will enable your library to accommodate the expanding technology and set the stage for future renovation or new construction projects.

We at the firm of Gee & Jenson, specialize in library design. We are devoted to the advancement of libraries. You will find that we have taken a genuine interest in providing services that are devoted to resolving inherent and potential problems related to library system designs that do not work. We can identify innovative planning solutions for your library related to your existing facility and renovation and new construction projects. We have taken a vested interest in our client's needs, interviewed the staff in an attempt to derive vital information that uniquely describe their library requirements. We recognize important contributions multimedia libraries deliver to the academic world, the community and our nation. There also is no doubt, that libraries will play an increasingly more important role over the next ten years.

The National Commitment

As an expression of our national commitment to an expanded role for libraries, we offer the following quote.....

"... to insure access for all areas and economic classes For industry to wire every classroom, every hospital and every library in the U.S. by 2000."

Vice President Al Gore

We can safely assume that over the next ten years, the information explosion will continue at an unprecedented pace. This explosion of information will be concentrated in formats that are only now being developed from innovations in software and hardware technology. These innovations offer exciting potential for a variety of users. The high concentration of information contained in smaller formats will make our libraries true resource centers that contain extraordinary amounts of information on almost every type and class of knowledge, field of study and human expression, including audio and visual experiences. Just think for a minute how extraordinary these changes in information access are going to be. Imagine also the dramatic change in resources you will be able to offer patrons compared to even a few years ago. The librarian's skill will be called on in ways that will challenge and stimulate their imagination regarding new ways to serve their patrons.

We have a recent example of the momentum that is building to turn these advances into expressions we can relate to -- and perhaps even be entertained by. For the first time in over 60 years, a major new entertainment studio was created. The distinguished producers, Katzenberg, Geffin and Spielberg, formed an extraordinary company. Their focus was to combine their amazingly-gifted talents to produce movies, animation and musical programs. With this combination of talent -- it is no doubt their efforts will be tremendously successful. However, they also specifically plan to produce something that will be truly ground-breaking for the entertainment field: Interactive Media. Never before has this kind of talent and financial resources been dedicated in such an early stage, as it is now to the development of Interactive Media. Interactive Media has had explosive growth in children and young adult segments with video games. Beyond video games, there have been only a few basic titles in this media so far. When developments have occurred, they've been primarily concentrated in children's material and reference sources.

The potential of what is ahead for Interactive Media, with Spielberg's creative talent, is amazing and explosive. Vast new experiences are ahead for this explosive industry. Certainly we can expect lots of entertainment-based material. However, the real benefit will be creative and market driven momentum to expand the interactive media segment into a legitimate place with conventional media such as books, movies, videos, and audio tapes.

Interactive media will be flexible and allow a variety of interactive options to a broad range of users. You will select whether to take a passive role or interactive one. The same interactive title can be entertaining or educational.

The public is demanding access to these new forms of media, specifically in the information services area.

What the Public Wants*

- 75% Information and Educational Services
- 61% Movies on Demand
- 55% Travel Networks
- 31% 500 Channels

* Source Jan. 1994 MCI survey

Information Equity

Librarians must realize the challenges they will face in providing access to this huge resource. The demand for hands-on interaction on the part of the Librarians, because of their specialized expertise and knowledge, will be necessary to provide direct assistance to patrons. This high allocation of time in service to patrons will be very important. The complexity of source format and its varying global locations will (for the near term at least) demand the professional expertise only librarians and multimedia libraries can provide. This explosion of new information is rampant and, unfortunately an increasing amount can be accessed only with skills and computer-based tools, unavailable to the average patron.

Access to this information will also be costly. More than ever, libraries will have the responsibility to maintain information equity for the public. Information equity means equal access regardless of ability to pay or technical skills. Librarians will serve as professional facilitators to access this vast information. Their skills and intelligence will be essential to assist the public in the navigation of some very complex routes to the information they need. Less of their time will be spent in the repetitive drudge type activities that now misuse so much of their time. Facilitating access is very important and librarians are going to be busy doing this job properly. To properly provide this service, librarians will need specialized systems and facilities that support this responsibility.

Library Facilities In Transition

Gee & Jenson are committed to doing everything possible, as engineers, architects and planners, to support Librarians in the planning and rethinking of new multimedia libraries. This process involves consideration of a variety of issues: from dealing with current needs -- to preparing for future needs. Librarians play a pivotal part in this transition. They are challenged with serving their patrons' needs (which are still heavily based on conventional information medias and sources) and also, must have the built-in flexibility to allow for the evolution of the new multimedia library that is more information diverse. The library facility will need to contain numerous types of interfaces to this diverse information. It will also need to have its own internal information grid, a system of hubs and connections that can allow the library to be dynamic as it serves a variety of patrons' requirements. Provision in the information grid for optional connection to fiber optics, coaxial or twisted pair cables will be important. Other provisions for connections to evolving technology such as dedicated FM and infrared band widths must be made as well.

1.0 THE VIRTUAL LIBRARY

The library we envision will be a Virtual Multimedia Library able to assume different characteristics and resource priorities based on the needs of the patron, academic program, or community priorities it serves. Depending on the user some would see its resources as oriented to fine arts or classic literature. Others still, would see its emphasis directed toward science, business, or international affairs. How the library is valued by the patron would be a function of the ease and extent to which they could access information. This access would occur through the use of a new library tool, the multimedia workstation. This workstation provides a study area devoted to the patron's own area of interest. Utilizing the station as a tracking system, the librarian could evaluate how on-site collections and outside sources are used by patrons (done in an unobtrusive manner, of course). From this evaluation, libraries could weed out those items that are of little demand but occupy valuable shelf space. Popular collections and on-line sources, could be expanded and optimized. The result would be a better use of resources at a time when every dollar must count.

We'll also see output devices that would allow production of paper or electronic copies of anything available from the library or its resources. Information could be personalized. Patrons could select fonts, sizes, and page formats to suit their preferences.

1.1 Keeping Pace with Evolving Information Technology

In an effort to keep pace with evolving information technology, areas of the library can be designated to allow for specialized devices that would enhance the patrons' interaction with library resources. In specially equipped rooms, individuals or groups could utilize high resolution and/or large screen projection devices. These interactive devices could be used in an educational setting to support video conferences or video seminars with practically any higher education facility, community group or library.

In reviewing the evolution of technology applicable to libraries, we must also envision the development of another form of information technology interaction -- simulators. Simulators are the next logical device for interacting with information. Simulators started out in the defense industry and were originally developed to enhance the quality of training, while reducing the time required to certify military pilots. This application proved to be highly effective. Through the application of simulators, provides a conservation of resources and an enormous amount of money that would otherwise be spent. A more important benefit is that pilots can use simulators to experience situations that could not be replicated any other way. Simulators deliver enormous amounts of information in the form of visual, audio, and special feedback to the user. A total immersion in the data set is possible. In the case of pilots, it's not unusual to see full sweats and exhaustion occur at the end of a training session in a simulator. "But why," you ask, "do I need to

provide for a simulator in my library?" Well, maybe you don't need one right now, but it's an evolving media that will be developed.

The founder of Blockbuster Video, Wayne Huizenga, has a prototype amusement park that includes two simulators: a jet and a race car. These two items are the biggest attractions in the park. The kids love them and these same kids will grow up with an appreciation for the simulator experience; an experience that will develop an expectancy for this level of media technology interaction.

The simulator makes sense for your future library. If you're still not sure, just consider what your predecessors probably thought when someone suggested that computer terminals would replace the card catalog and videos, or that VCR's and computers would be available in the library. A proactive library is one that is preparing for the future and also tracking the information and media technology. Simulators, in some form, is to be considered when planning for the evolving information technology.

1.2 Adapting Libraries For The Changes Ahead

Once we have an understanding of the potential for the future role of libraries, the next step is to determine what can be done with the multimedia library facility. Librarians should consider what new physical features are needed and the expense associated with incorporating these features. Start by looking at where libraries are now from a physical prospective. Most would agree, that technologically, most libraries are average. You can find some PC's and dedicated data terminals plus CD-ROM drives and a computerized card catalog. To install these systems, unless the library was less than 5-6 years old, was a process of compromising system needs with the limitations of the facility. Equipment locations had to be selected based on where there was a power source or a telephone line and with a sight line to visually supervise its use. Installing these systems would have been easy if only there had been an empty chase or spare conduit. In past designs, there was no way to anticipate the information revolution. No provisions were made for providing extra telephone lines or clean power. Planning for the future meant adding an extra telephone line and two or three extra circuit breakers. Planning for the future now encompass a great deal more, especially with regards to renovation projects and new construction.

The multimedia library of the future is tasked with an enormous amount of responsibility. These responsibilities cannot be avoided. Somehow, we must find a way for libraries to support an expanded multimedia role.

As an architect, I can't fully appreciate the professional and managerial adjustments that are going to be necessary for librarians. I can, however, offer views on tools we can make available in the form of equipment and spaces in library renovations and new design programs that will help you with your new responsibilities.

1.3 Important New Features in a Multimedia Library

To transition into a contemporary multimedia library means taking a fresh look at the functions that occur now and the changes necessary to adjust to the new multimedia role.

1.3.1 Equipment

We recognize that multimedia equipment has unique requirements to be properly utilized. It needs dedicated areas to function at its best. The equipment is expensive and needs some form of supervision. An ability to provide instructions on its use is also required. Another characteristic is multimedia equipment always involves connections to other devices. CD-ROM towers, servers, printers, and networks are a few of the interconnections that must occur.

1.3.2 Utilizations

By the very nature of its use, multimedia equipment demands a focused involvement by the student or patron. Exploiting the equipment's capabilities requires concentration and a fixed amount of time to interact with it. Interface shells are varied in their protocols and users of one system will find it difficult to use another configuration without training and practice.

1.3.3 Optimizing Multimedia Equipment and Its Utilization

There are always people who can function in the most hostile environments. They can tune out distractions without affecting their performance. Some can also put aside awkward computer arrangements and peripheral locations. These types of people are the exception, however. What is important is to establish study and work environments that are conducive to efficiency. To properly capitalize on the library's investment in equipment and deliver the highest potential for utilization, specialized areas and environments must be created within the library.

1.4 New Spaces to Support Multimedia Operations

The following areas are proposed to facilitate optimum performance for multimedia libraries and their students or patrons. Suggestions are also made regarding equipment and square foot requirements. Your actual library may find that combinations of these areas into one space or other equipment configurations would work better for your needs. You and your architect will know best.

1.4.1 Training Center

Training is very important to advancing multimedia interaction. There are too many systems to expect that the average patron will be able to sit down at a multimedia workstation and immediately function. Training at different levels is necessary to compensate for the variety of computer experience patrons and students have. A facility capable of providing ongoing training oriented to different levels of multimedia literacy will increase the use of the library. An ideal location for the center is combining it with the community room of the public library. For an academic library a dedicated facility may be appropriate. This training center could also be used as a multimedia viewing area or conventional classroom.

Basic equipment would include:

- Video projection equipment capable of direct connection to a computer and VCR
- Data links to the telecommunications room
- Ten or more ports for multimedia workstations to tie into the library's data grid
- A satellite connection.

Size requirements for both facilities will be in excess of 400-600 SF.

1.4.2 Group Multimedia Production Room

The information imbedded within multimedia titles can be diverse. The format for its presentation can be broad, ranging from a computer monitor to wall size screens. Also with multimedia, different skills, some analytical, some creative can be orchestrated in the development of a multimedia product that would be impossible for many individuals to accomplish. Therefore, an area that allows groups to produce multimedia product is an asset for the multimedia library.

Accommodating this need in either the academic or public library is best accomplished with a separate room. Equipment in the room would include:

- Multimedia workstations
- Video projection equipment
- Access to the library data grid
- VCR
- Sound amplifiers
- Sound insulation materials

Typical area should be 150 to 200 SF. Multiple production rooms would be essential in academic facilities.

1.4.3 Output Center

Another benefit of technology has been development of output devices that allow multimedia products to be converted into printed and electronically formatted material. The biggest advances have been in printers and plotters. Rich color on a variety of paper sizes are now possible at reasonable cost per page. The equipment, however, is expensive. A full featured multimedia library will need to have an output center that allows users to produce hard copy or electronic versions of multimedia productions and sessions. Arrangements can be made to block output of material that is copyrighted. Modest printing software is available to produce cost-accounting for hard copy devices. This allows the user to be charged for copies and helps minimize abuse of the output center equipment and supplies. The following types of equipment would be located in the Output Center:

- Color dye-sublimation printer
- Color ink jet printer
- Full-size ink jet or laser plotter, color capable
- High-speed black and white laser printers
- Color copier
- Black and white copier
- VCR
- SyQuest drivers
- Digital tape drivers.

Area requirements - 250-300 SF.

1.4.4 Multimedia Support Center

Given the complexity of multimedia systems and their expense, specialized management of these resources is important. A single location configured to coordinate the use of these systems is preferred. Patrons can also arrange for use of specialized equipment and support at this center. Another location is needed for management of the output center. Usage can be monitored and fees collected where applicable. This facility could be configured in a separate room or as an island type center. Operations and roles would include:

- Multimedia server management
- Telecommunications resource management
- Data bank and CD-ROM tower management
- Output center controls and cost accounting
- Security functions.

Area requirements could be as small as 150 SF in an island configuration or 150-200 SF in a room dedicated to this use.

This location will require specialized data grid access and a centralized location.

1.4.5 Multimedia Classification Room and Receiving Center

For some public libraries and most academic libraries another support function should be considered. Inclusion of a specialized multimedia receiving and classifications center will serve an important role in the proper collection and categorizing of multimedia products when they arrive at the library. These products require special knowledge when receiving shipments, verifying their integrity and classifying them in a manner that ensures they are associated with the proper multimedia equipment and usage controls. Equipment within this operations would be:

- Multimedia workstation
- VCR's
- CD-ROM's
- Audio decks.

Areas required for this operations will vary with the volume of material they process. A minimum would be 150 SF.

1.4.6 Archiving Center

An archiving center is another multimedia function that deserves consideration. Such a center would be essential for academic libraries and optional for public libraries. This facility would be available to make electronic archive records of numerous types of electronic and hard copy data. New digital archiving technology allows capture of a spectrum of media from printed to video and storage on electronic or very compact and stable tape formats.

Equipment would include:

- Multimedia workstations
- CD-ROM's
- Color scanner (large bed)
- Black and white scanner (large bed)
- DAT drive
- WORM drive
- VCR
- Audio decks.

Area allocation - 250-300 SF.

1.5 Introducing New Multimedia Functions Into Libraries

The new possibilities for spacial relationships and functions are illustrated in the accompanying graphics. Actual layouts and equipment for a specific library may involve issues not considered in this study. Also, juxtapositions relative to other library functions can be done in a manner sensitive to the actual library program and budget.

There are, however, basic considerations for renovations and new construction projects. As these new functions are introduced into the library, we need to understand how the changes will effect each project category.

1.6 Renovation Projects

Making changes to existing facilities to accommodate these new areas in renovation projects is the most difficult. Each renovation project will have unique characteristics to address; however, all have common issues that need to be understood before anything can be done:

- What horizontal passageways are available and accessible?
- How accessible are these passageways to the telecommunications room or area?
- Are the locations where the multimedia equipment is going near the passageways?
- Is there an uninterruptible power source available?

After each concern is understood, a program to incorporate a data line or grid can be developed. Cost to install these improvements will depend on the following:

- Extent of barriers (beams, columns, floors, and walls) that have to be penetrated to route the grid.
- Relationship of the telecommunications room to the outside.
- Extent of access available to the passageways.
- Quality of the electrical system.
- Type of construction.

Actual cost will vary from building to building and there is no rule of thumb to estimate the cost on a per workstation basis. Another cost modifier is the type of facility the upgrades are to be installed in. The older the library the more expensive it is to adapt. This is especially true if you have a facility classified as "historical."

1.7 New Construction

Most librarians we talk to shudder at the thought of trying to incorporate provisions in new construction programs for the information revolution. They have a number of apprehensions that compound their ability to move ahead including the following:

- Anxiety in selecting the best data system.
- Things are changing so fast I'll make a mistake.
- How do I know how to configure the system to be flexible?
- It will be too expensive.
- Technology ambivalence.

While we understand that immense changes in information technology are going to happen, a great deal of the apprehensions above are unfounded when logic is used. Most of the concerns are associated with making a decision that could later become a bad one due to change. The most significant design provision then that needs to be made is for change. Once that is solved most of the other concerns assume a lesser priority. How then should provisions for the new multimedia functions and future change be incorporated into the new library?

1.8 Flexibility Tools

Try to do everything you can in the design stage to accommodate change that could be necessary at a later date. If your library design is set up for change, then you're flexible. Multimedia designs need flexibility more than any other trait. Flexibility is relative. How flexible a facility will be is a function of many different aspects of its design. Layout, building services, internal circulation characteristics and structural elements play an important role in the facility's ability to accommodate change.

Fortunately there are certain elements that can be included in the design that will allow change to occur later. Most involve careful selections of building systems and equipment that enhance flexibility and provide for future change.

The following pages outline building systems and equipment that, if used in the facility, will greatly increase the flexibility of the facility to adapt to new systems and functions you want to include in the future.

1.8.1 Flexibility Enhancements (General, Electrical, Structural, Telecommunications Room)

(General)

- Vertical Chases
- Pitched Roofs
- Spare Conduits
- Accessible Ceilings
- Data Grid
- Telecommunication Room on Exterior

(Electrical)

- Oversized Load Center
- Spare UPS Circuit
- Surge Protection Circuit
- Spare Conduit
- Phone in Electrical Room

(Structural)

- Steel Frame
- Bar Joist or Open Truss Floor and Roof Structure
- Attic Space
- Floating Floor Slab

(Telecommunications Room)

- Oversized Equipment Mounting Board
- Room Size a Minimum of 50 Square Feet
- Spare Conduit to:
 - Roof
 - Exterior
 - High Use Areas
- Air-Conditioning

2.0 CRITICAL MULTIMEDIA

Support Requirements

In preparing for change, our research indicates that there are support requirements that will apply to practically any of the advances in telecommunications and information technology. They are:

- A clean power supply.
- An uninterruptible power source.

Regardless of the technology and no matter how complex the internal designs or functions of future multimedia systems, they will need power and a means of communication. It is not difficult or expensive to include these provisions in libraries, as you'll see below.

2.1 Power Features

An effective power source can be included with very little increase in the electrical budget. At the very least, the electrical system can have the capacity to add a system later. There is usually no extra cost associated with this future add-on feature. The same is true for an uninterruptible power source. Overall extras may add 5% to 10% more to the electrical budget.

- Spare Electrical Panel Capacity
- 2-Level Power Surge Protection
- UPS (Uninterruptible Power System)
- Clean Power

2.2 Communication Systems

A well-designed communications system will result in a properly wired library. Listed below are a few of those characteristics:

Characteristics of a Properly Wired Library

- Total Flexibility for New Information Technology
- Easy Access to Data Grid
- Easy Access to Exterior
- Centralized System Management
- Has a Variety of Community Room Information Options
- Supports a Range of User Skill Levels

It is relatively easy to provide tremendous communication flexibility in the wired library. Make sure you can accommodate any communication conductors that could be used. To do this simply provide a flexible data grid. There are lots of options to consider in making this choice. The choices range from wired to wireless. Specifically they can be grouped as follows:

Data Distribution Types

- Wireless
- FM
- Infrared
- Wired
- Twisted Pair
- Coaxial
- Fiber Optics

For each of the systems there are characteristics and provisions to consider in order to properly integrate the data grid into the facility. These are basics that, when incorporated into your selection process, will make the system easy to use in the future as well.

2.3 The Importance of the Data Grid

The glue that holds all this together is the data grid. The grid is the definition of information flexibility. Everything that can happen will be a function of the grid design. A few related observations:

Data Grid Facts

- It's cheap
- It's easy to install during construction
- It never wears out
- You never have enough
- It's your insurance for the future

2.3.1 Data Grid Hubs

Serving as the intersections and access points in the data grid are the hubs. Typical hub locations are:

- Telecommunications Room
- Circulation Desk
- Reference/Information Desk
- Staff Work Room
- Important Data Grid Access Points in Library
- Lobby
- Children's Area
- Community Room
- Study Areas
- Reference Section
- Catalog Area
- Periodicals Area
- Staff Work Room
- Librarian's Office

2.3.2 Telecommunications Room

Of all of the design features to incorporate into a new facility, one of the most important is the telecommunications room. This is where the information funnels into and out of the library. It's like an electronic version of the circulation desk. No library will be able to properly function without one. Its features are detailed below:

Telecommunications Room Features

- Oversized Equipment Mounting Board
- Room Size a Minimum of 50 Square Feet
- Spare Conduit to:
 - Roof
 - Exterior
- High Use Areas
- Make It Air-Conditioned

The impact in cost and area allowances you should make:

- \$1,000 does wonders
- Slight increase for furnishings
- How much space does it require?
- 2% increase in total library square footage
- More room for a telecommunications center
- A minimum of 50 square feet.

Summary

We hope you will benefit from our suggestions for "Multimedia Centers: Concepts for the Future." This overview is merely a illustration of the possibilities and important issues to ensure multimedia service and flexibility. Actual aesthetic concepts have not been discussed. As library architects, believe this is best addressed on an individual project basis. Our topic is broad and we are certain that some items may have been overlooked. We trust this material may serve as a guide for your library planning. We at Gee & Jenson look forward to assisting you in any way that we can, should require further information on any aspect of this material. We would love to hear if any of our suggestions prove useful.

Good luck on your new multimedia plans!

The Telecommunications Lag or Libraries that are Telecommunications-Challenged

81% with
Carpet

19% with
No Carpet

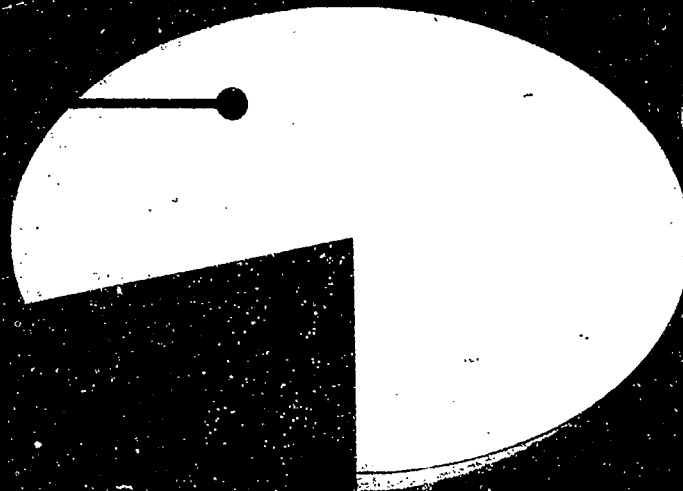

Libraries with Carpet*

68% with
Data
Telephone
Lines

32% with
No Data
Telephone
Lines

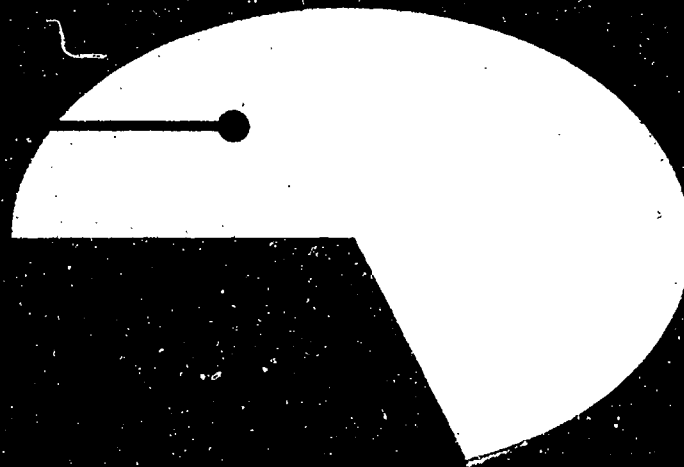

Libraries with Telephone Lines*

* Source: Winter '94, School Library Media Quality, Carol Truitt, Survey of 146 Libraries and Media Centers.

Multimedia Control Center Suite

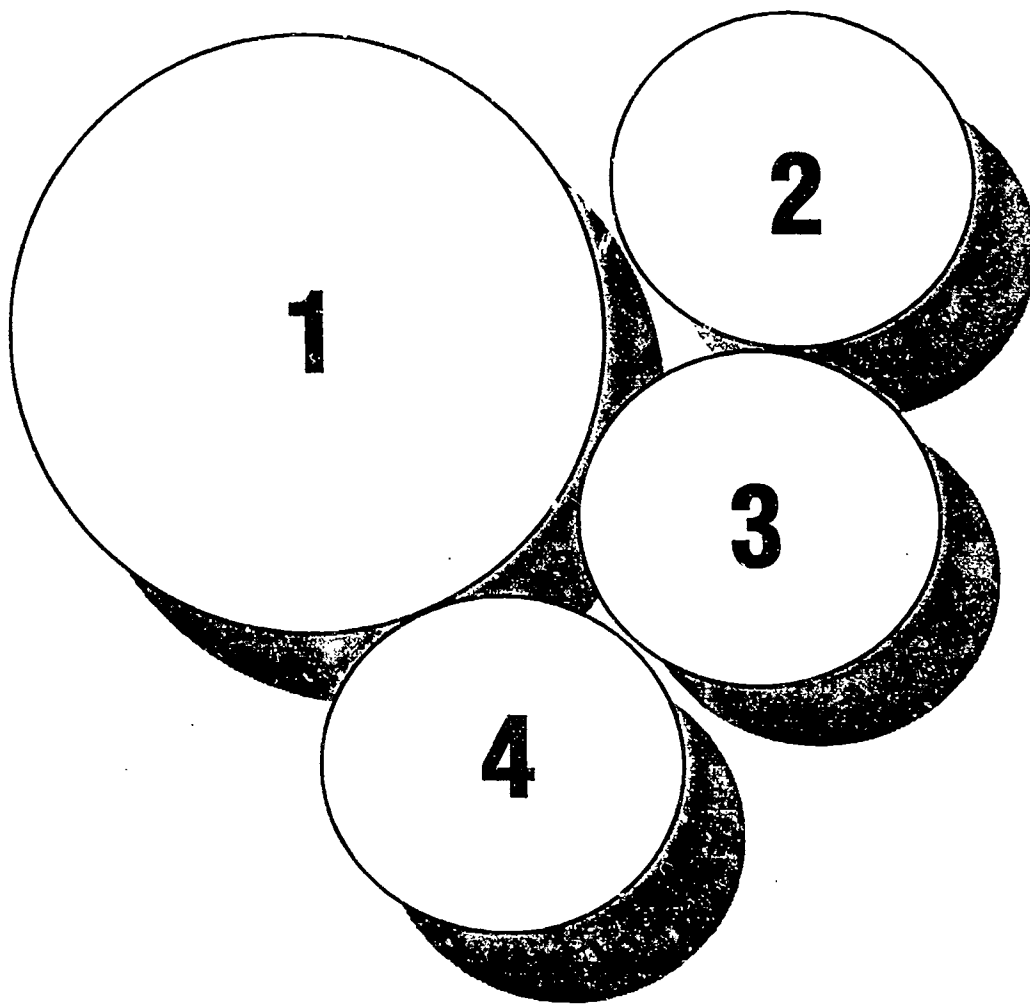

1. Multimedia Control Center
2. Receiving and Classification Room
3. Archiving Room
4. Media Equipment Service Center

Multimedia Lab and Production Suite

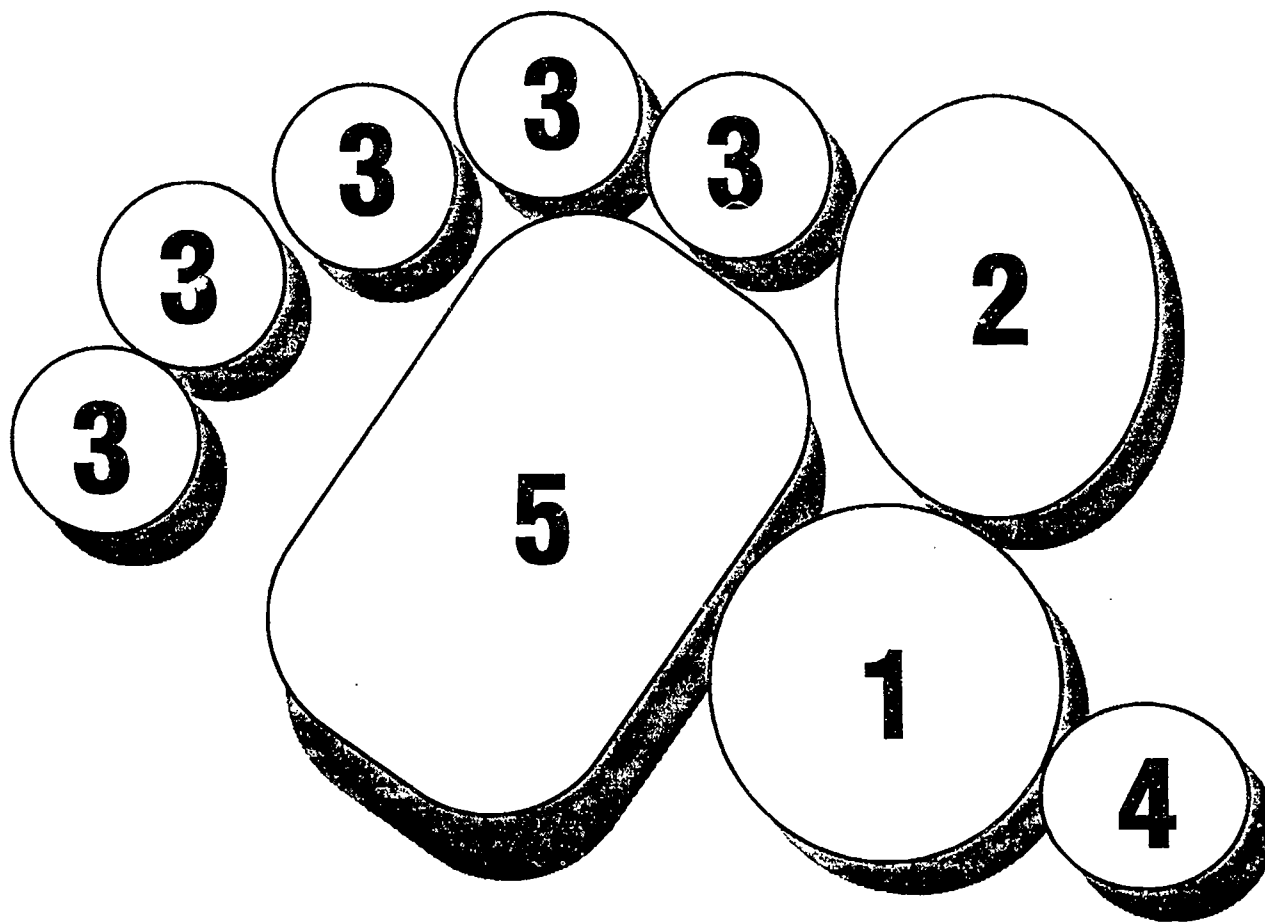

1. Multimedia Control Center
2. Output Center
3. Multimedia Labs
4. Telecommunications Room
5. General Library Circulation Area

Multimedia Suite

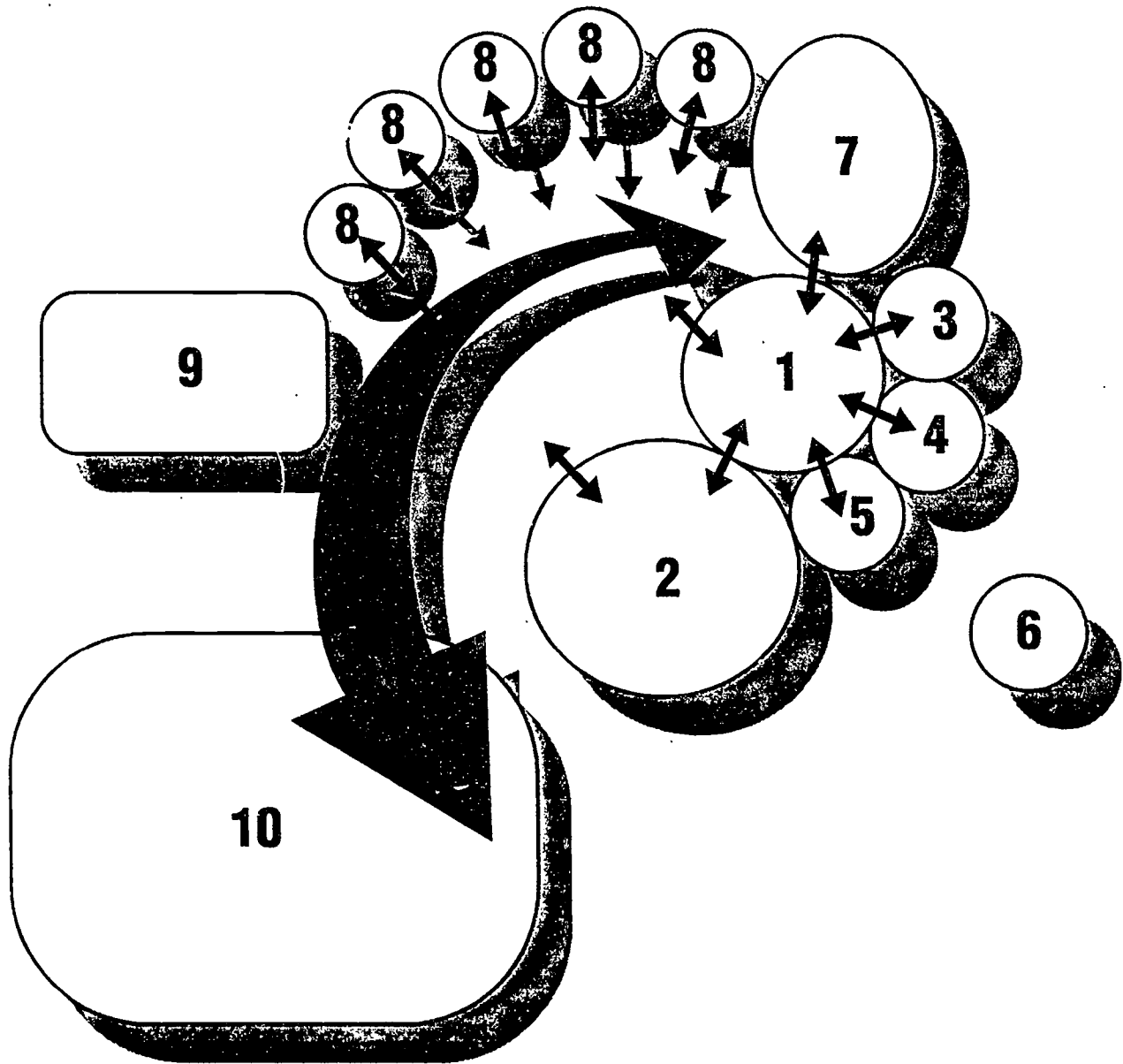

- | | |
|--------------------------------------|--------------------------------------|
| 1. Multimedia Control Center | 6. Telecommunications Room |
| 2. View Room and Training Center | 7. Output Center |
| 3. Receiving and Classification Room | 8. Multimedia Labs |
| 4. Archiving Room | 9. Open Multimedia Workstations Area |
| 5. Media Equipment Service Center | 10. General Library Circulation Area |

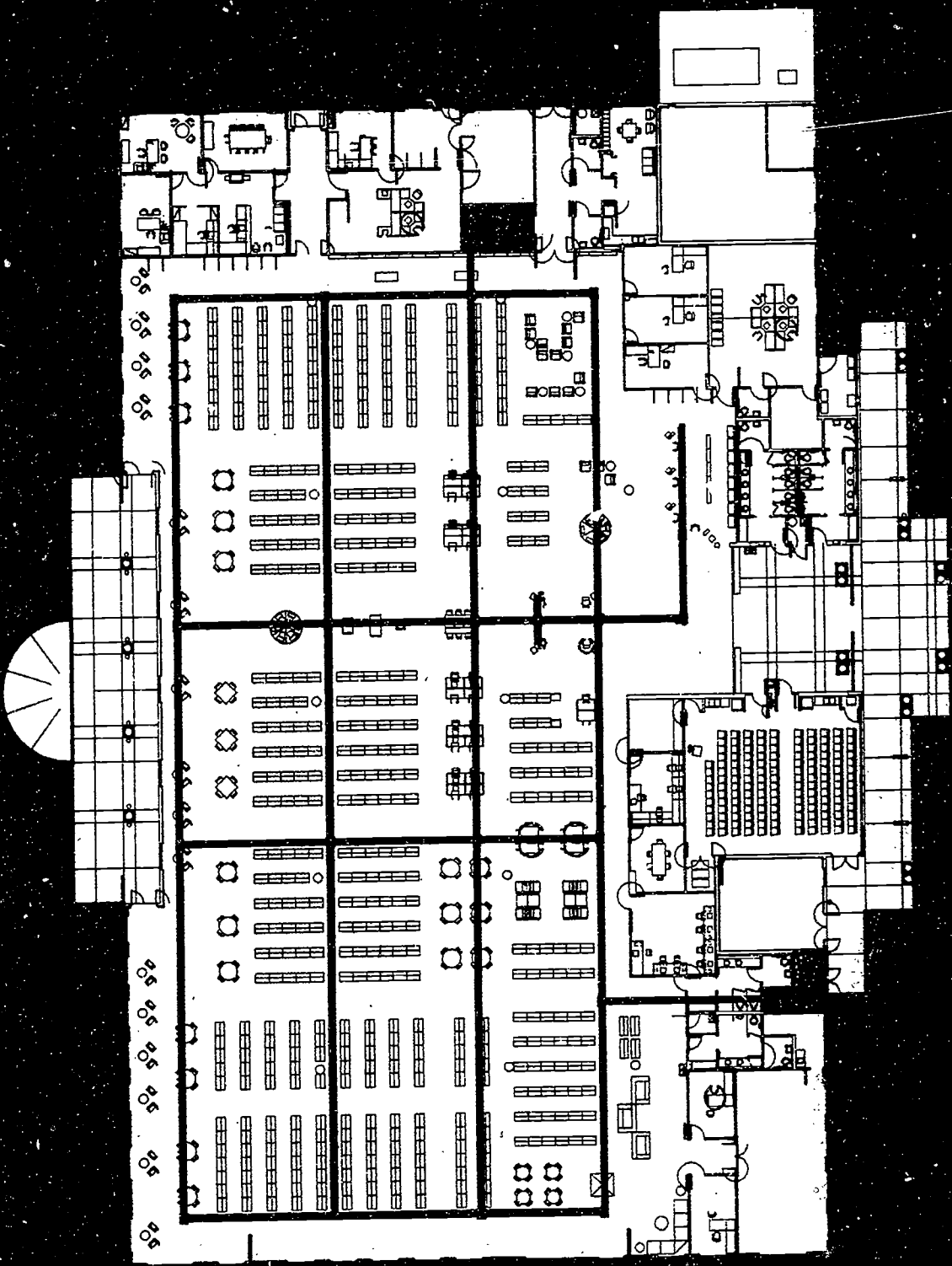

In-Floor Systems

- Telecommunications Room
- Satellite Telecommunications Room
- Main Electrical Room

The Harold G. Zopp Memorial Library, Spring Hill, Florida

BEST COPY AVAILABLE

3.0 CHECKLIST AND WORK SHEETS

The following section contains various aids designed to help organize the renovation and design process for multimedia facilities. We have included information that should help you in your discussion with consultants, facility personnel and your peers. This material is not all inclusive, so don't depend on the use of any one item as the only basis for a decision.

If you have any questions, we would like to hear from you.

3.1 Important New Multimedia Areas

in New Libraries

- Telecommunications Room
- Data and Power Grid
- Multimedia Receiving and Classification Room
- Multimedia Browsing Stations
- Multimedia Production Suites
- Multimedia Theater (Formerly a Programs Area or Discovery Center in a public library)
- Multimedia Control Center
- Multimedia Small Group Study Room
- Archiving Center

3.2 How to Critique a Multimedia Design Proposal

3.2.1 Critiquing a New Design for a Media Center

Libraries are designed and construction documents prepared in a series of steps referred to as design steps. Plans evolve in a series of stages that progressively add detail to the overall design being developed by the architect and his/her client. As a librarian, you don't need to be qualified to examine the minute detail that goes into a complete set of construction documents, but you do need

to ask questions. As I have previously said, one of the most important factors that you can strive for is flexibility. Once you have a flexible design, functional, hardware, or system modifications can be accommodated.

Be strong in your role as a client. You should be in charge of the process and the architect expects it. The architect will respect your enthusiasm and respond positively.

Sample questions to ask when critiquing a plan for a new design are:

- What provisions have been made for a dedicated telecommunications room and how big is it?
- Does the plan incorporate a data and power grid? If so, where is it and what type is it?
- Are there expansion circuits available in the power panels?
- Are there spare conduits and wire ways or chassis in all locations within the building?
- Is there a separate power circuit for surge protection specifically set up for telecommunications and workstations?
- Is there a connection for future data terminals in the lobby?
- Is the community room set up for teleconferencing and access to the data grid?
- Is there sufficient room for at least a 50% expansion of equipment within the telecommunications room?
- Does the structural system allow flexibility for future modifications?
- Can the HVAC system be adjusted to accommodate changes in usage?

3.2.2 Multimedia Operations to Look For

1. Does the plan have the following room spaces?
 - A telecommunications room dedicated for that use
 - A community room
 - A multimedia production room
 - A multimedia viewing room
 - Multimedia capable small group meeting rooms
 - Multimedia capable study carrels
 - A feature-rich lobby with kiosk
2. Are each of these rooms connected on a data grid and power grid?
3. Is there a reserve of at least 25% of the gross floor area available for dedicated multimedia operations in the form of workstations or other devices allowing interaction with multimedia devices or is there a space which can be converted with relative ease to provide for that same percentage?

3.2.3 Critiquing Existing Facilities as a Candidate for a Media Center

A Work Sheet and Checklist

Introduction

Use of existing facilities to accommodate a media center is usually a function of economical, practical or physical factors. In the renovation process you can seldom achieve the overall performance and flexibility opportunities possible in a custom designed facility. However, there are a number of facilities with many years of life remaining that may offer an option for additional space where money isn't available for a new facility.

The material included in this work sheet and checklist is structured to help identify the relative ease or complexity that will be associated with the renovation process for a specific building. The items are organized by groups of common elements within a building. Only physical items are part of this work sheet and checklist. Other issues such as site constraints, regulation restrictions and neighborhood location can only be evaluated by you. It is an absolute requirement to have a structural engineer evaluate the capacity of floors in multi-story buildings to support design loads for a media center. If the capacity is below minimums, it is sometimes possible to augment the structural systems without significant expense.

A scoring system ranks the relative degree of complexity the system found within the building will impose on a renovation program. For the purposes of this process it is assumed that the actual elements found within the facility are in sound condition with sufficient serviceable life remaining for a minimum of 10-15 years.

To start this process, familiarize yourself with the Work Sheet and Questionnaire first, then ask appropriate questions of the individual most familiar with the facility. The best choices in order of contact would be:

1. Building owner or manager
2. Building maintenance staff
3. Repairman that services the specific elements in the building, such as A/C repairman, electrician, etc.

If for some reason none of these contacts are available, an architect in your community would probably be willing to take a hour or so and help you complete the Work Sheet and Questionnaire.

When you have discussed the building with one of the individuals above, then tour the facility to see it for yourself and confirm the answers you received and resolve any unanswered questions you have.

Structural Systems

The building's structural systems support materials that form the envelope separating interior spaces from the exterior and each other. What these systems consist of and how they are assembled is important to understand in a renovation program. Some structural assemblies are far more accommodating than others. Power and data grids will be introduced into the building, and the primary barrier they face will be the building's structural system. In most cases the owners of the building or maintenance technicians may be of assistance in identifying systems listed in the categories below. If it is difficult to determine, a more detailed analysis can be obtained from the services of an architect or professional structural engineer.

The following categories include the majority of building materials and/or assemblies of material found in facilities from 1920 to present. If you encounter a situation not covered by the work sheet, then check the one that appears closest. If you find multiple systems are in the same building, select the system that appears to occupy the most area.

Structural Systems (Cont.)

Floor Types**

Select	Point
<input type="checkbox"/> Steel bar joint with concrete floor topping* (multi-story)	20
<input type="checkbox"/> All concrete (monolithic system of floors, beams and columns) (multi-	16
<input type="checkbox"/> Concrete slab on grade (always in a single-story application)	8
<input type="checkbox"/> Precast concrete (prefabricated pieces of concrete elements manufactured	12
<input type="checkbox"/> Timber or wood joist	0

Total Point Value _____

** Prior to decision to convert a facility to a media center, multi-floor structural floor systems must be analyzed to verify their ability to support new design loads.

Interior Wall Systems

Select	Point
<input type="checkbox"/> Drywall over metal studs*	10
<input type="checkbox"/> Drywall over wood studs	9
<input type="checkbox"/> 3 coat stucco over metal lath over wood framing	3
<input type="checkbox"/> Partition style concrete block	
<input type="checkbox"/> Load bearing masonry or brick or clay tile	6

Total Point Value _____

*Represents the optimum condition.

Total Value Recap

	Point
Floor Type	_____
Wall Type	_____
<i>Total Point Value</i>	_____

BUILDING SYSTEMS

Telecommunications

Substandard telecommunications for a library is like trying to get to the moon with a compass; it relies on inferior hardware and you will never get where you want to go. Unfortunately, the telecommunication services for most buildings consist of a few beige boxes and maybe a punch down strip for extensions. Most of the time this basic system is served by several 4 pair telephone lines that have been pushed through a hole in the wall or ceiling. The better ones may have the wires in a ½" conduit. Saddest of all though, is this basic system is usually found on one wall in the janitor's closet or utility room. Space is limited and little care is given to protection of its meager components. Fortunately, modifications to create adequate space for a telecommunications room is fairly easy. Review the conditions below to establish which one comes closest to those found in the existing facility.

<u>Select One</u>		<u>Point Value</u>
<input type="checkbox"/>	A separate telephone room with room to double the size of the existing equipment. The room is located adjacent to an outside wall.*	15
<input type="checkbox"/>	Telephone equipment is located in janitor's or utility closet.	8
<input type="checkbox"/>	There is no isolated room for telephone equipment. The telephone panels are apparent or are scattered in various locations.	4
	<i>Total Point Value</i>	<u> </u>

*Represents the optimum condition.

BUILDING SYSTEMS (Cont.)

HVAC System

It would be the exception to find that the HVAC (heating, ventilating and air-conditioning) system in an existing facility could easily be converted to support a new use as a library media center. Air-conditioning, dehumidification, dust control and heating standards are far more complex in a media center facility than the typical library or other type of building. HVAC systems usually are difficult to modify and still get the correct performance when complete. Therefore, a system conversion is probably going to be involved and complex.

Review of existing conditions are still important in order to estimate the degree or difficulty that will be encountered in an upgrade program. Illustrated below are the basic system configurations to look for in the review:

<u>Select One</u>		<u>Point Value</u>
<input type="checkbox"/>	Centralized HVAC system with primary equipment located in a separate mechanical equipment room.*	15
<input type="checkbox"/>	Multiple HVAC units located in various places through the facility.	7
<input type="checkbox"/>	Separate heating systems and separate air-conditioning systems located throughout the facility. Each system has its own temperature control device.	0

Total Point Value _____

*Represents the optimum condition.

BUILDING SYSTEMS (Cont.)

Electrical Services

Electrical services within any building are always of concern when a new use is proposed. In most cases the original system will not be capable of supporting a new use without significant upgrades. New electrical and fire codes are always an issue. Unless the facility is less than five years old, expect compliance problems.

The items listed below are structured to classify the relative ease or difficulty that will be encountered in an electrical upgrade. Since some issues associated with the evaluation will be technical, most librarians will want to have the assistance of an electrician in completing the inspections of electrical systems prior to selecting their answers.

<u>Select</u> <u>One</u>		<u>Point</u> <u>Value</u>
<input type="checkbox"/>	The building's electrical entrance and distribution panels are in a single location with provisions for expansion. These panels are located in a separate electrical room. Power from the electrical panels are routed to the various lighting, equipment and receptacle locations in conduits or other dedicated cable ways.*	20
<input type="checkbox"/>	Electrical panels are mounted on an exterior wall (inside the building or outside). No separate electrical room is provided. There appears to be room for expansion.	10
<input type="checkbox"/>	Electrical panels are inside a room or space that also functions as another use, such as HVAC, telephone or janitorial closet. No provisions for electrical service expansion have been made and there doesn't appear to be space available for new electrical panels.	3
<input type="checkbox"/>	The electrical system does not have its own room and shows signs of numerous modifications with portions of the original system appearing to still be in use.	0

Total Point Value _____

*Represents the optimum condition.

BUILDING SYSTEMS (Cont.)

Lighting Systems

The lighting requirements for a media center are specialized. Therefore, it would be nearly impossible to find a lighting system containing enough serviceable elements to allow an economical conversion in a renovation program. As a result, no evaluation of the lighting system is going to BE a factor in the ease or complexity of a facility renovation. Existing lighting will be discarded except for possibly in a service area. No points are assigned this area.

	Point Value
<i>Total Point Value</i>	<u>0</u>

Rest Rooms & Plumbing Systems

Rest room sizing regulation and accessibility standards mandated by the ADA can be expected to require extensive rest room modifications when a renovation program is implemented. Therefore, it is generally assumed that the rest rooms will go through a major modification no matter what the use or the condition of the existing facilities were in. Therefore, rest room review should not play a very significant role in your evaluation. No points are assigned this area.

	Point Value
<i>Total Point Value</i>	<u>0</u>

BUILDING SYSTEMS (Cont.)

Roofing

A watertight roof is an obvious asset for any building. However, in a conversion program there are other aspects of the roof that make the process of upgrading the HVAC system and introducing a data and power grid either more difficult or easier. The key factor is accessibility to the space underneath the roof. The easier it is to gain access to the roof and modify or install new systems, the more economical the process will be. The ideal roof is a pitched roof with gable ends. After that, a pitched roof with hips. The least desirable type is a flat roof. This is also the very type of roof that leaks the most. The steeper the pitch, i.e., a 9-inch on 12-inch versus a 5-inch on 12-inch, the better. The descriptions below illustrate the various roof types you may encounter in a prospective facility.

<u>Select One</u>		<u>Point Value</u>
<input type="checkbox"/>	Pitched roof with open trusses and minimum of 5 on 12 pitch. Gable end condition.*	20
<input type="checkbox"/>	Pitched roof with open trusses and minimum of 5 on 12 pitch. Hipped at ends.	15
<input type="checkbox"/>	Single pitch roof (no ridge, it slopes in one direction only), minimum of 5 on 12 pitch.	3
<input type="checkbox"/>	Flat roof.	0
	<i>Total Point Value</i>	<u><u> </u></u>

*Represents the optimum condition, but the higher the pitch the better.

EXISTING FACILITY

SCORE SUMMARY

Recap the score from Work Sheet and total them in the appropriate space. Compare your total with the point ranges assigned to each category of renovation complexity.

Building System	Point Value
• Structural Systems	
Floors	_____
Walls	_____
	Total _____
• Telecommunications	_____
• HVAC	_____
• Electrical	_____
• Lighting (No Points)	_____ 0
• Rest Rooms & Plumbing (No Points)	_____ 0
• Roofing	_____
	Total Points _____ *

* See Renovation Categories on next page to rank your facility's ease or difficulty as a candidate for renovation.

RENOVATION CATEGORIES

	<u>Score Range</u>
A. A strong candidate for renovation. The facility contains systems which will reasonably accommodate changes necessary for a media center. A below-average renovation cost will be associated with the project.	85-100 pts.
B. An average candidate for renovation. Some systems are marginal and will either require significant modifications or add to the complexity of the conversion process. This project will require an average to above-average budget.	50-84 pts.
C. A marginal to poor candidate for renovation. Multiple building systems will either interfere with the renovation program or require significant modification abandonment. This will probably be a very expensive renovation program. Prior to any decision to go any further with a project in this category, an architect should be retained to conduct a further evaluation of the facility.	7-49 pts.

DESIGN PHASE

Steps in the Design of a Library

Introduction

In the design of any facility architects prepare the drawings for the building following the phases listed below. Each phase is organized to collect information and develop solutions in a logical manner with the final product a set of drawings, referred to as Contract Documents, that the general contractor can build from. Once you are familiar with these phases you will be more comfortable with the design process and able to operate in a more effective role as a client.

1. **Programming-** This is the very first time that you meet with the architect to start planning the library project. Information regarding the project budget, site, specific needs within the library and all of the space requirements are discussed and listed in the program. All requirements for each room and piece of equipment in the library should be listed. The programming phase should take no longer than two to four weeks if it is well organized. Remember, the ideas developed during the programming phase are used to start the actual designs that occur in the next phase, the Schematics Design.
2. **Schematic Design -** All the work and detail developed in the programming phase is used now to prepare site and floor plans and elevations of the exterior appearance of the library. All the rooms and their relationships to each other are shown in this stage. A summary of total square footage the plan requires is provided along with an estimated cost of construction.

While it is not usually done for other types of facilities, we highly recommend that provisions for the data grid be illustrated on the plans in this stage.

3. **Preliminary Design -** Preliminary Design is one of the most important stages in the development of a complete design package. Preliminary Design is the stage of the design process in which architects and engineers transform schematic designs from basic sketches into drawings containing more detail. These drawings start to incorporate mechanical, electrical and structural systems into the plan. It is at this phase that detailed provisions for the data grid must be finalized. The next phase is preparation of contract documents and all decisions made in the preliminary design phase will be incorporated in the contract document package. The cost estimate is revised based on the latest information in the preliminary designs.

4. **Contract Documents** - This is the phase that prepares drawings used to build the library. Details, schedules, and wall sections are developed during this phase. These are the documents used to bid the project and the ones the contractor uses to obtain the building permit and then build the building. Once again a revised cost estimate is prepared to confirm the project on budget.

5. **Bidding & Negotiations** - The completed contract documents are distributed to interested general contractors in order for them to prepare their bids. The architect administers this process and answers any questions. When bids are submitted, negotiations are held with the lowest qualified bidder to reach a final construction contract amount. The next step is to obtain a building permit and start construction.

4.0 CHECKLIST

4.1 Steps to Take to Wire Your Library for Multimedia

Introduction

The items listed below are included to help in planning your library for the demands that the information revolution is causing. The design process is complex for any library. You will need an experienced architect with a good library background. Your architect will have many other items to review with you. We have included those that are especially applicable to the unique requirements of advanced telecommunication systems. This list is not comprehensive but should still help you plan and design a library that is ready for these exciting advances.

When using this information, please don't hesitate to call with any questions. We will be happy to assist you in any way we can.

4.1.1 Programming Phase

- Accept the fact that communication technology and media format will be under constant change.
- Prepare a written description of the data system and data grid (wired or non-wired types) you plan to use. Generally state your library's future system plans and expectations.
- Communicate to your architect the need for flexibility in your library's data grid and hubs that operate with the grid.
- Insist on meeting with the design team's electrical engineer to express your telecommunication system's requirements and expectations for grid flexibility. Don't believe anyone who says this will be expensive and you can't afford it. It's simply not true. Data grids are not that expensive and you can't afford to be without one.
- Require a separate telecommunications room of at least 50 square feet and make sure it is air conditioned. A telecommunications room should have lots of extra conduit to the exterior and to internal hubs that serve the library.
- Have your architect arrange a joint meeting with representatives of your local telephone company and long distance carrier. This meeting will be useful to learn of the capabilities to provide interactive data communications services and to accommodate your library's long-

range needs. Ask how they are prepared to react to new information technology and what plans they have to provide backup services should their primary system fail.

- Insist on spare junction boxes and wire ways in circulation and reference/information desk cabinetry.
- Require your library program to include existing or future provisions for:
 - An output room to contain printers, video cassette recorders, audio recorders and provision future devices. Include lots of clean power, spare conduit and air conditioning.
 - Teleconferencing facilities, primarily in your community room.
 - Provisions for patron interface terminals in your lobby and at your book drop.
 - Flexible collection space to accommodate displays for new media types that will need to be accessible to patrons.

4.1.2 Design Phase

- Require a 3/4 inch diameter by 8 foot long grounding rod be installed in the telecommunications room.
- Require that the provisions for the data grid be included and shown in the schematic designs. This isn't normally the way it is done, but in a library it is especially important to understand from the start of design how the floor plan will accommodate this grid.
- In the Design Development Phase check with the architect and electrical engineer to review the latest data grid consideration, telecommunications room space allocations and air conditioning solutions that have been incorporated into the design.
- Make sure all your telecommunications equipment will fit in the room. While this may seem odd to state, it needs to be pointed out that sometimes the electrical engineer will not fully understand the physical requirements of telecommunication systems. When this happens installers have a difficult time making room for everything in the telecommunications room. The best thing to do is have the architect call a meeting with key equipment suppliers, the telephone company and the electrical engineer to review the space requirements and allocations for the system you will use in the library.

- In the Contract Documents Phase review the final design of the telecommunications room and data grid within the building. Especially understand how the grid bypasses physical obstacles such as steel and concrete beams and columns, masonry walls and concrete floors. Ask to be shown samples of the trunk system (conduit, floor ducts or cable trays) and junction boxes that will be used in the data grid.
- Require a separate schedule of telecommunications equipment/system that will be included in the library. The schedule will list equipment type, power requirements, physical size, manufacturer and any special location (floor or wall) needs. This schedule must be included in the contract documents.
- Require that the electrical engineer prepare a functional diagram indicating the relationship of telecommunication elements within the system. This diagram must be included in the contract documents.
- In the Contract Documents Phase insist that grid terminations be readily accessible and protected from debris or accidental blockage or closure. Insure that each grid termination has a junction box.
- Require the electrical engineer include surge protection equipment on the primary power entrance. We recommend an even more conservative approach of requiring a second level of surge protection for circuits that service the telecommunications system.
- If you are in an area where lightning is common, have a lightning protection system included in the design. Please note this doesn't take the place of a surge protection system. It will help protect other basic equipment and your library from severe lightning damage but will not protect your telecommunications system.
- Include a separate surge protection system on your communications lines. This will protect sensitive circuits from dangerous voltage surges in the communications lines.

4.1.3 Project Closeout Phase

- Require that the responsibility for installation of your data system equipment, conductors and other components rest with the general contractor. As a single individual responsible for the system, the general contractor will not be able to blame you or others should there be difficulty on start-up.
- Insist that the specifications require that project closeout is only possible after a successful documentation of the data systems and grids performance has been demonstrated and

sustained for at least a week. This should be done with all telecommunication systems operational and all building systems (HVAC, fire alarms, security) functioning in normal cycles.

- Require a letter from the general contractor certifying that all spare conduits have been cleaned and are free of debris.
- Require labels to be placed on exposed parts of the telecommunications grid and on junction boxes to identify their use and destination within the library.
- Require As-Built Data Grid Plans be supplied by the general contractor.
- Finally, inform your librarians and maintenance staff about the locations of the spare data grid locations and remind everyone of their responsibility to protect its access points from obstruction or damage.

4.1.4 Telecommunications Room Features

- Minimum 50 Square Feet
- Air Conditioning
- Fire Protection System
- Well Lighted
- Grounding Terminal
- Spare Conduit
- Telephone
- Isolated Electrical Panel
- Adjacent Outside Wall

4.2 Characteristics of a Properly Wired Library

- Total Flexibility for New Information Technology
- Easy Access to Data Grid
- Easy Access to Exterior
- Centralized System Management
- Variety of Community Room Information Options
- Supports Range of User Skill Levels

4.3 Important Data Access Points in Library

- Lobby
- Children's Area
- Community Room
- Study Areas
- Reference Section
- Catalogue Area
- Periodicals
- Staff Work Room
- Librarian's Office

4.4 Information Kiosks*

Basic menu items and services available on a touch screen computer located in the lobby.

- **Basic Information**

- Hours of Operations
- Floor Plans
- Rest Room Locations
- Key Media Center Features
- Special Programs & Events

- **Resource Information**

- General Resource Categories Available
- On-line Services Available
- Electronic Data Bases
- Archives & Special Collections
- Graphics Illustrating Resource Locations

- **Library Resource Policies**

- Access Procedures
- Assistance Available

- **Patron/Student Questionnaire & Suggestions**

- *** System Hardware**

- Touch Screen Monitor
- 486/50 Mhz
- 100 MB Drive
- 8 Megs RAM

5.0 CABLES AND RACEWAYS DESIGN FOR MULTIMEDIA LIBRARIES

We at Gee & Jenson understand the need for infrastructure and planning, and apply this understanding to cabling and raceways for many diverse projects.

This portion, although slightly technical, is provided to assist you to plan your communications needs for your up coming library and to assist your consultant to plan and design a Structured Cabling System combined with a Raceways Distribution System (telecommunications and power grids) that will serve you for years to come.

A Structured Cabling System is a distribution system that arranges cabling and raceways in a logically coherent and economical fashion so that a wide variety of applications can be supported and modified/expanded in the future without major expense.

Today's communications technology isn't just expanding, it is literally exploding. Just a few years ago copper was the primary medium for cable communications. In the 1990's fiber optic cables broaden the horizon of communication daily, as data speeds increase in quantum leaps and message-carrying capabilities expand in complexity and volume.

To keep pace with the information highway and the vigorously expanding technology, we at Gee & Jenson have been asking ourselves questions that have yet to come from our clients.

5.1 What Kind of Cable Should You Use?

Although this may change as copper cabling standards continue to evolve, Unshielded Twisted Pair (UTP) can be used for almost any conceivable application except the very high data rates for which fiber optic is needed, see Table "Evolution of UTP".

EVOLUTION OF UTP		
Date	Data Rate	Application
1975	4 KHz	voice/PBX
1977	2.5 Mbps	ARCnet
1985	4 Mbps	Token Ring
1989	10 Mbps	10BASE-T
1991	16 Mbps	16Mbps Token Ring
1992	20 Mbps	ARCnet+
1993	100 Mbps	TP-PMD
1995	155 Mbps	ATM (Projected)

Mid-range, mainframe, voice, Ethernet, Token Ring, Arcnet and most other communication systems are all capable of using UTP as a highly reliable transmission media.

UTP cabling is so popular you could almost call it the LAN's Ubiquitous Transmission Preference. It is rapidly eclipsing its coaxial (COAX) and shielded twisted pair (STP) rivals.

- It is easy to work with
- Flexible
- Low cost
- Small diameter
- Lightweight
- Simple to connect and terminate

5.2 What are the Advantages of Using Fiber Optic Cables?

The application of fiber optic cables in high performance communication circuits is growing because of operational and economical advantages over copper circuit. The advantages are:

- High Bandwidth
- Lighter Weight
- Noise, Surge, and Electromagnetic Interference (EMI) Immunity
- Security

5.3 How Does Fiber Optic Cable Differ From Copper Cable?

Generally, an optical fiber consists of a hair-thin strand or core of optically PURE GLASS surrounded by another layer of less pure glass called the cladding.

The cladding provides the difference in refractive index that allows total internal reflection of light through the core, which in turn carries the light signals.

An optical fiber is always described by both the core and its cladding (62.5/125), the first number always defines the core diameter (see Fig. 1).

Fiber Optic has three (3) basic performance types:

1. *Single Mode Step Index*

Characteristics:

- Carry signals over long distance before requiring regeneration.
- Band width in Giga Hz.
- Relatively inexpensive in comparison with associated equipment.
- Electronic equipment at either end of Fiber Optic is expensive.

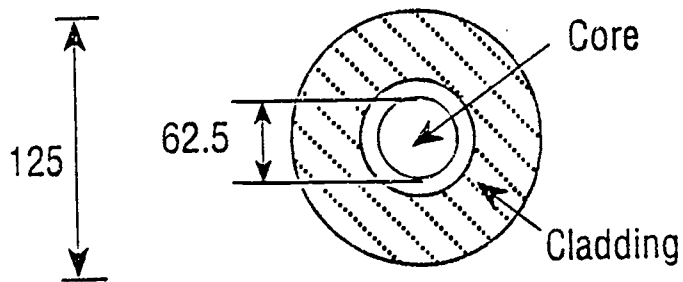

Multimode graded-index

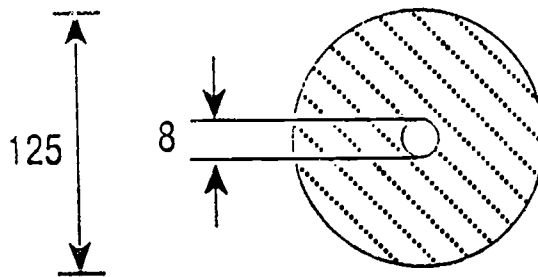

Single-mode step-index

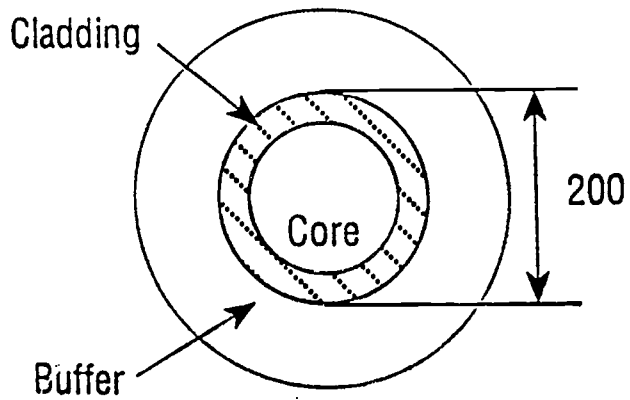

Multimode step-index

Figure 1.

2. *Multimode Graded-Index Fiber*

Characteristics:

- Carry signals over shorter distance.
- Band width as high as 600 Mhz.
- Electronic equipment at either end of Fiber Optic is LESS expensive than Single Mode Step Index Fiber Optic.

3. *Multimode Step-Index Fiber*

Characteristics (See Fig 2)

- Has very specific applications in the manufacturing and process industry as well as in the medical profession.
- Band width from 10 to 30 MHZ.
- High tensile strength and excellent resistance to static fatigue
- Relatively inexpensive.
- All the three (3) types of Fiber Optic cables are available for PLENUM rated and RISER (non plenum rated) applications.

5.4 What Is A Broadband System?

The use of broadband CATV as a multi media communications conduit enabled Local Area Network (LAN) data to be transmitted on a coaxial (COAX) medium with other services such as home networks, public services access, manufacturing automation, (see Fig. 3).

Broadband data communications systems compared to baseband systems, such as Ethernet or Token Ring provide a sophisticated and flexible backbone solution. The technology is based on Cable TV signaling and is sometimes referred to as CATV for Community Antenna Television.

The broadband backbones treat video or data transmissions as if they were a TV channel. Hence, its advantage as a data backbone is its ability to simultaneously carry multiple services on a single cable. Each service, (see Fig. 3) is assigned a unique channel or frequency on the cable. Each

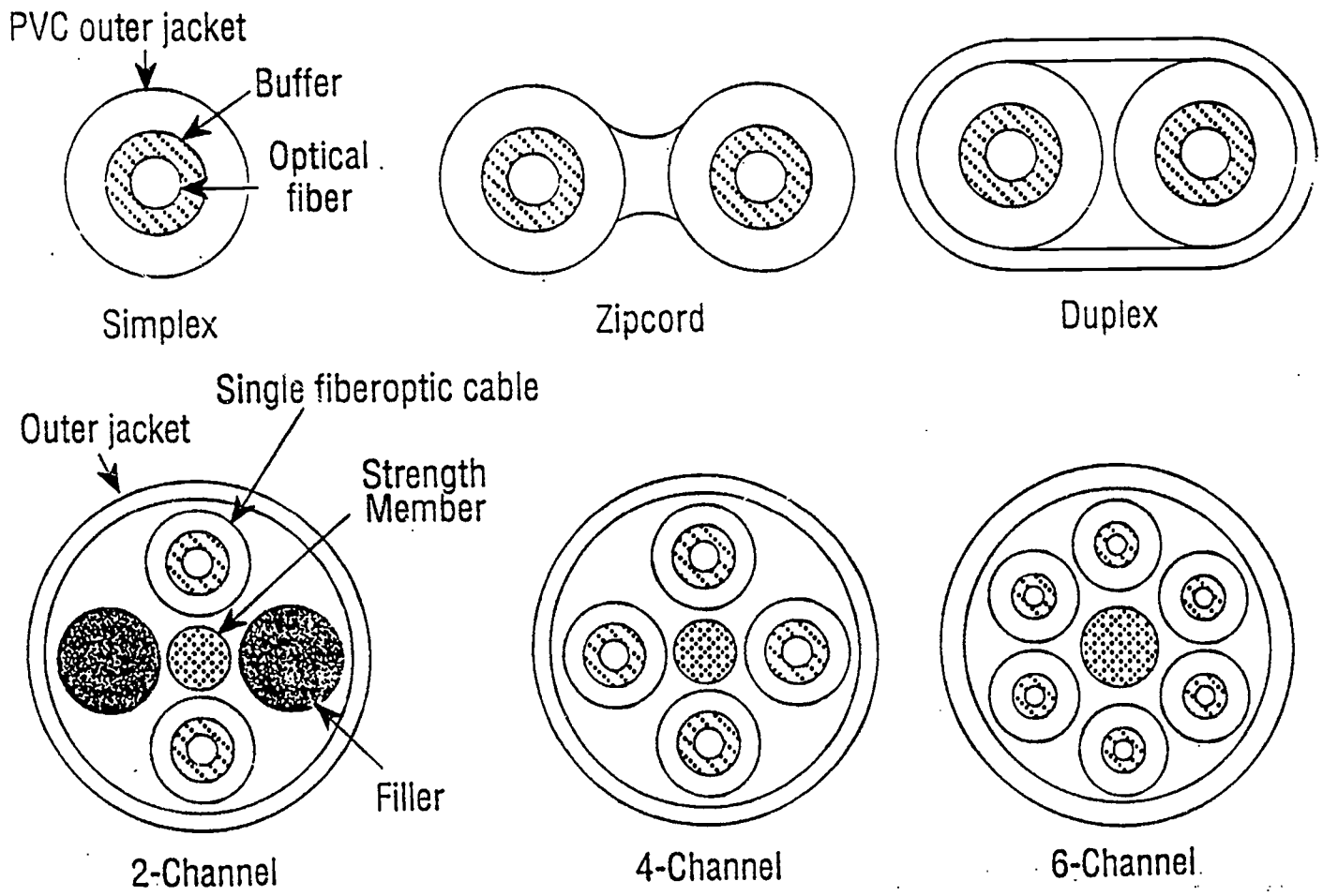

Figure 2.

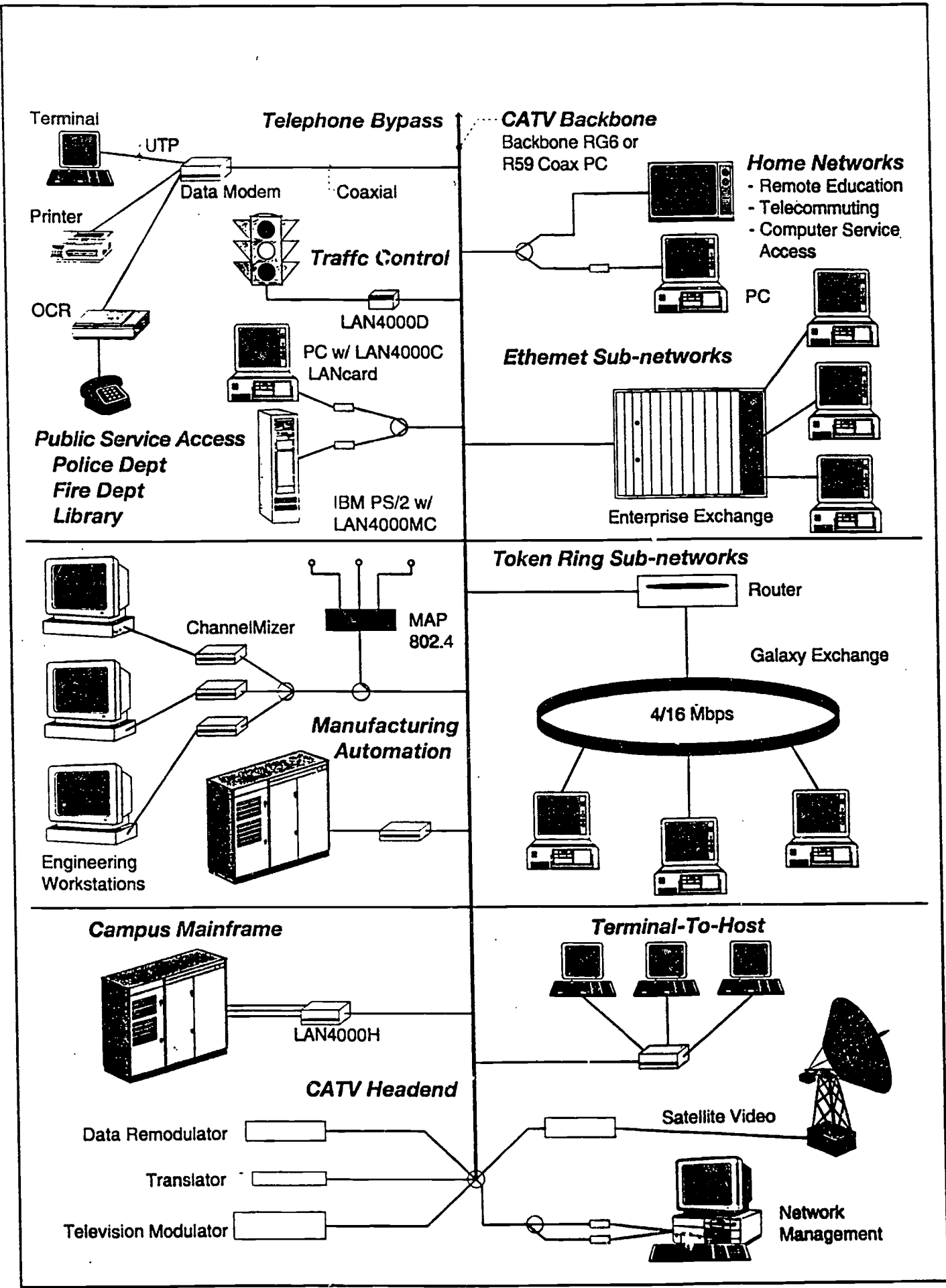

Figure 3.

broadband data service receives a particular channel assignment based on increments of 6 mega Hz, (see Fig. 4). The available broadband cable system bandwidth is typically 0- 450 mega Hz. In this case, the total number of services that could be simultaneously would be 75.

The data transmitted on broadband cable system require one channel for forward direction transmission and one channel for reverse direction transmission for data transmission.

5.5 What Are The Advantages and Disadvantages of Using Broadband/Coax Cables?

Besides the benefit of allowing multiple services on a single cable, broadband signals can travel farther than baseband network. The standard baseband Ethernet can travel along a single cable for a length of 500 meters. By using Ethernet-on-broadband modems, the maximum distance of Ethernet can be stretched to 3.75 Km, which eliminates the need for remote satellite telecommunications room in some applications.

5.6 What Are the Deciding Factors to Use Fiber Optic Cables vs. UTP?

Ultimately, the deciding factors between the use of Fiber Optic versus UTP In-Building Backbone Subsystem are:

- Cost
- Distance
- Speed

See Table "*Network Media*" for comparison between UTP, STP, COAX and Fiber Optic.

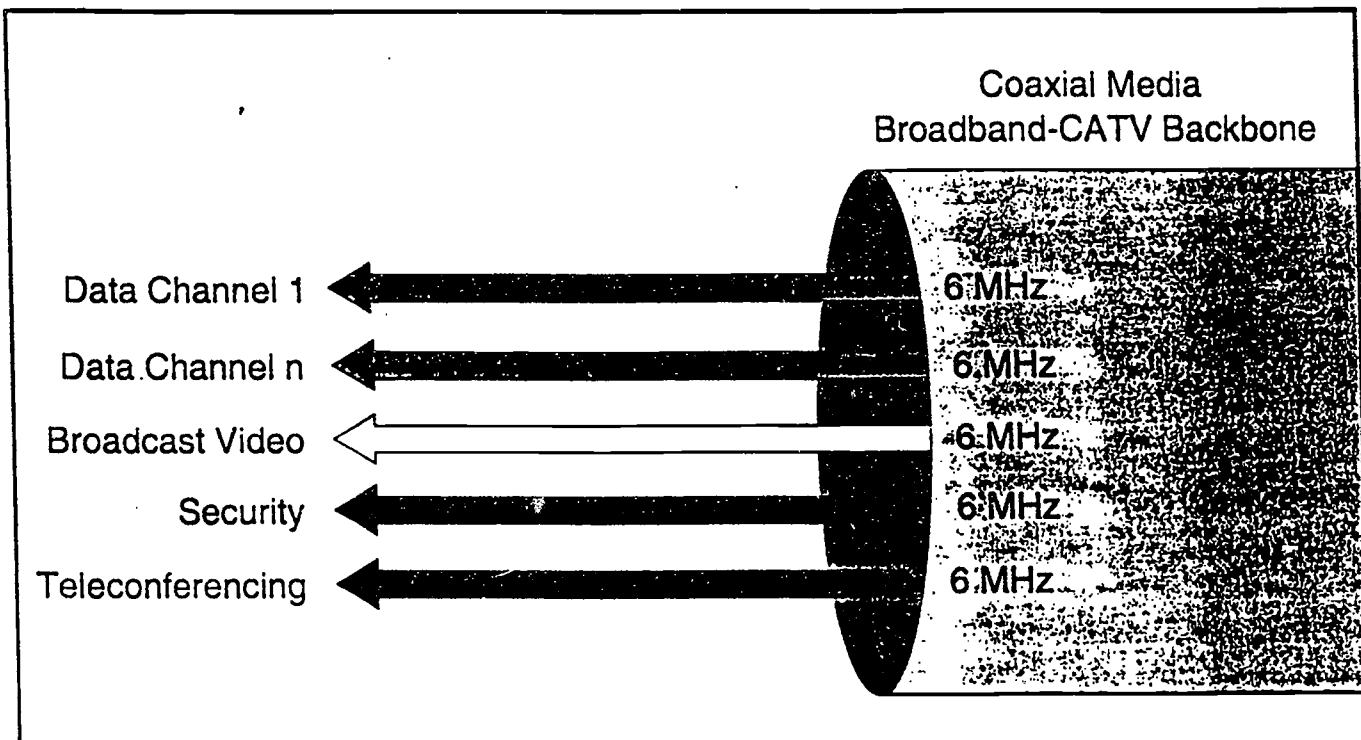

Figure 4.

BEST COPY AVAILABLE

NETWORK MEDIA				
Type of Media	Cost	Cost	Speed	Typical Application
Unshielded twisted pair	Least Expensive	Short	Fast Enough	Ethernet
Shielded twisted pair	Expensive	Short	Very Fast	Token Ring
Coaxial cable	Inexpensive	Medium	Very Fast	Ethernet, ARCnet
Fiber optic	Most Expensive	Very Long	Fastest	All

5.7 What is the Most Economical Way to Wire the In-Building Backbone Subsystem?

All UTP and Fiber Optic cables used in In-Building Backbone Subsystem are wired in a manner that resembles a physical STAR, (see Fig. 5) with the appropriate VOICE or DATA Main Distribution Frame (MDF) located in the center or hub of the star.

- The maximum allowable length for UTP In-Building Backbone cables is 800 m (2,624 ft.).
- The maximum allowable length for Fiber Optic In-Building Backbone cable is 2000 m (6,560 ft.).

5.8 Where Should the Telecommunications Room Be Located in the Facility?

- Always ensure the cable from each data jack is a home run cabled back to the hub patch panel.
- Cable DOES NOT exceed 100 meters (300 ft.) in length. This length is supported under IEEE 802.3 and IEEE 802.5 on UTP.

5.9 What Size Telecommunications Room Will I Need?

- A good rule of thumb is one telecommunications room can service up to 20,000 square feet of floor space or a maximum of 200, 10 ft. by 10 ft. cubicles.

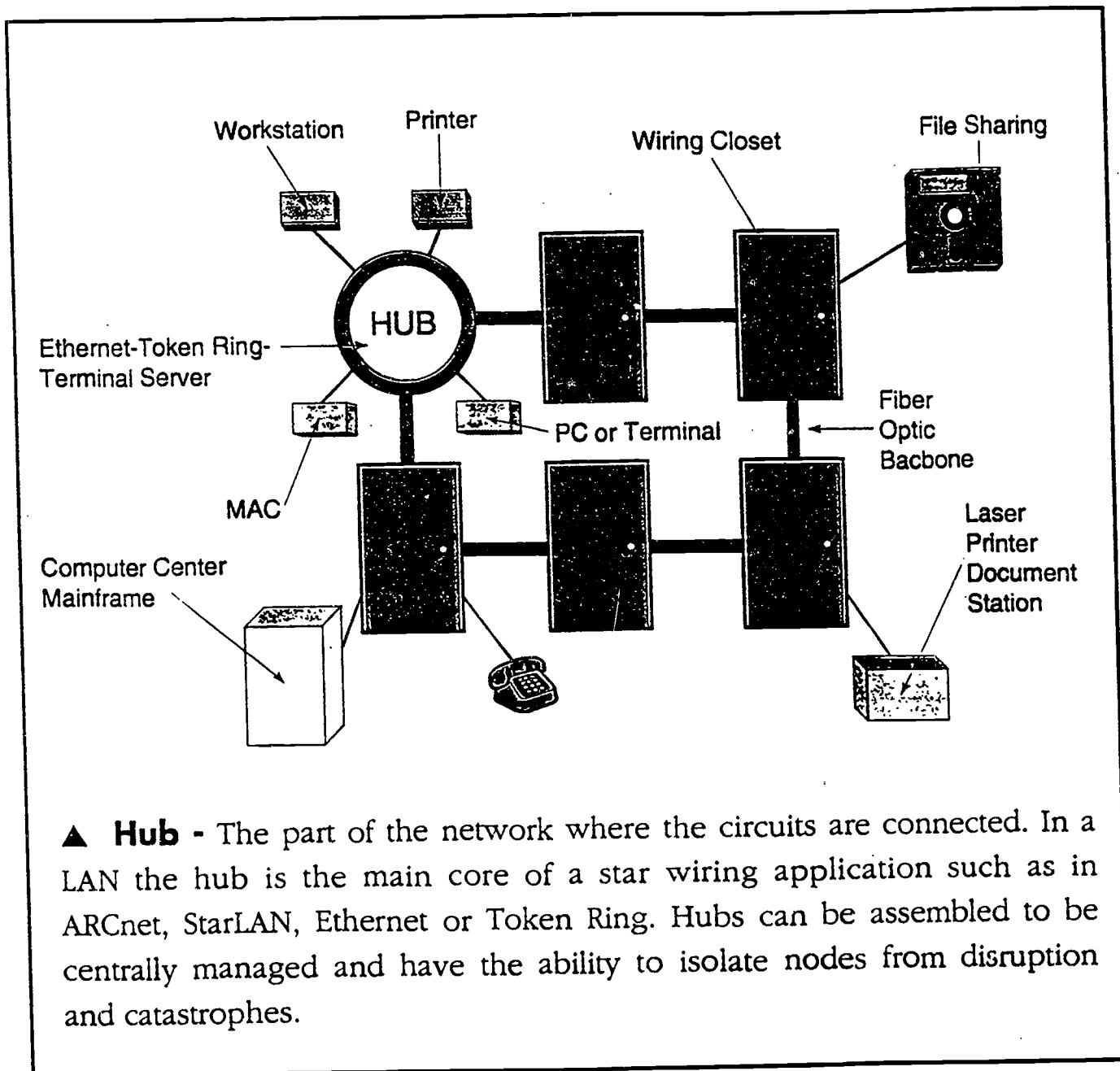

Figure 5.

▲ **Hub** - The part of the network where the circuits are connected. In a LAN the hub is the main core of a star wiring application such as in ARCnet, StarLAN, Ethernet or Token Ring. Hubs can be assembled to be centrally managed and have the ability to isolate nodes from disruption and catastrophes.

BEST COPY AVAILABLE

- If a floor has more square footage than this, multiple satellite closets on each floor should be set up, each connected to a central closet on the floor where the system is housed. All the central closets are then connected to the main communications closet via the system backbone.
- Allow one square foot of closet floor space for every 250 square feet of usable floor space.

5.10 What are the Conditions that Affect Cable Location Selection?

The following are only a few of many special conditions that may affect cable and location selection:

- Large sources of heat
- HVAC equipments and return air plenum
- Magnetic materials, such as pipes or structural members, close to large cables carrying a heavy current loads
- Corrosive materials
- Flame and radiation resistance
- Moisture
- Thermal conductivity of soil or other surrounding medium
- Depth of buried cable.

5.11 What Causes Interference or Static Noise?

In general, any device or power line carrying current or generating a magnetic field with high speed transmissions will cause interference and induce noise. A list of noise sources is provided below:

- Fluorescent lights
- AC power lines
- Arc welding equipment
- Electrical motors
- Heating and ventilation equipment
- Time clocks and electronic door locks.

5.12 What Can I Do To Minimize Voice/Data Signals Distortion and Failure?

Even the best designed communications wiring systems can go haywire if not properly installed. It is important to understand that certain external influences or improper installation techniques can easily cause low voltage signals to distort. Some of these external influences are:

Routing of Cables

- Run cables over corridors
- Use straight runs
- Run parallel to building contours

Cable Support

- Use mechanical means to support cables, such as cable tray and hangers
- Group cables

Separation From Sources or Electromagnetic Interference (EMI)

- Comply with the minimum separation from 480 V power sources as shown in Table "Minimum Separation Distances of UTP From Sources of EMI"

Grounding and Bonding

- All applicable regulations for grounding and bonding as defined by codes should be strictly adhered to.

Condition	<2kVA	2-5kVA	>5kVA
1. Unshielded power lines or electrical equipment in proximity to open or nonmetal pathway.	5 in. (127 mm)	12 in. (305 mm)	24 in. (610 mm)
2. Unshielded power lines or electrical equipment in proximity to a grounded metal pathway.	2.5 in. (64 mm)	6 in. (152 mm)	12 in. (305 mm)
3. Power lines enclosed in a grounded metal conduit (or equivalent shielding) in proximity to a grounded metal pathway.		3 in. (76 mm)	6 in. (152 mm)

Table. Minimum separation distances of UTP from sources of EMI.

5.13 Why Install Category Five Communications System?

The Electronic Industries Association (EIA) and the Telecommunications Industry Association (TIA) have established Five cable categories as listed in Table "THE EIA/ TIA CATEGORY SYSTEM" of those We recommend use of category Five for the following advantages:

- Flexibility to support almost any application
- Ability to handle speeds up to 100 Mbps
- Flexibility for all topology
- Greater noise immunity
- Support for greater distance.

The EIA/TIA Category System	
Category One	Intended for basic communications and power limited circuit cable. There are no performance criteria specified in EIA/TIA SP-2840 for EIA/TIA 568.
Category Two	Low performance UTP. Typical applications include voice and low speed data. Not specified in SP-2840, 568 or TSB40.
Category Three	Applies to UTP cables and associated connecting hardware with transmissions characteristics up to 16Mhz. Typical application include 4 Mbps Token Ring and 10 BASE-T.
Category Four	Applies to UTP cables and associated connecting hardware with transmissions characteristics up to 20 Mhz. Typical applications include 16 Mbps Token Ring and low loss 10BASE-T.
Category Five	Applies to UTP cables and associated connecting hardware with transmission characteristics up to 100 Mhz. Typical applications include 16 Mbps Token Ring Emergency Application TP-PMD and CDDI.

Category Five makes good economic sense too. A recent AT&T study indicates installed Category Five cable is only a 20 percent premium over Category Three cable. The cost of cables in any network communication system is usually much less than five percent of the total cost. See Table "Price Comparison of Installed UTP Cables."

Price Comparison of Installed UTP Cables (150 Ft. Horizontal Runs)					
Cable Type	End User Price	150 Ft. Lobe Price	Installation Labor 1.25 Hr. @ \$45.00/ hr	Total End User Price	Premium Over Cat. 3
Cat. Three	\$0.07/Ft	\$10.50	\$56.25	\$66.75	N/A
Cat. Four	\$0.11/ Ft	\$16.50	\$56.25	\$72.75	9%
Cat. Five	\$0.16/Ft	\$24.00	\$56.25	\$80.25	20%
Source: AT&T 1993					

5.14 What is Structured Cabling System?

A structured cabling system is a distribution system that arranges cabling and raceways in a logically coherent and economic fashion so that a wide variety of applications can be supported and modified/expanded in the future without major capital expense.

The key elements are:

- Planning ahead avoids future problems.
- Think twice and wire once.
- The conduit to the future is the electrical conduit.

Instead of creating a horrible cable mess in your ceiling by allowing your cabling system to grow haphazardly as needs arise, a structured cabling system (SCS) can be designed today to handle your needs well into the next decade. Although the initial cost may be higher, the long-term savings in both your money and time of a structured cabling system design are well worth the effort.

Today, most owners of large buildings and campuses recognize the need for structured cabling systems that handle a number of diverse communications systems and support equipment from multiple vendors.

What has made SCS necessary?

- The growing popularity of the LAN. The flexibility of the LANs is a nightmare for management. Some surveys indicate that up to 10% of the users on a typical LAN will move every month. In a non-structured wiring system, every move might require pulling new cabling, which would limit the network flexibility and add to its material cost, not to mention the labor cost.
- Labor rates are always rising. It is far too costly to send technicians out year after year (not to mention day after day) to pull new cabling. SCSs should be designed to last five to ten years without major rewiring.
- Information is vital for every business in today's world and the cabling plant is the foundation over which this information passed. We can no longer afford to have million dollar pieces of equipment passing invaluable, mission-critical information over second rate cabling systems.

A structured cabling system's design is defined by analyzing the following elements: (see Fig. 6)

- System architecture
- System configuration
- Face-plate configuration
- Space Requirements
- System infrastructure
- System cabling.

5.15 System Architecture

Communications-system architectures are defined by:

Logical Topology

Logical topology describes the order and the paths by which information flows. It permits analysis of locations where information must be transferred and allows establishing transfer methods.

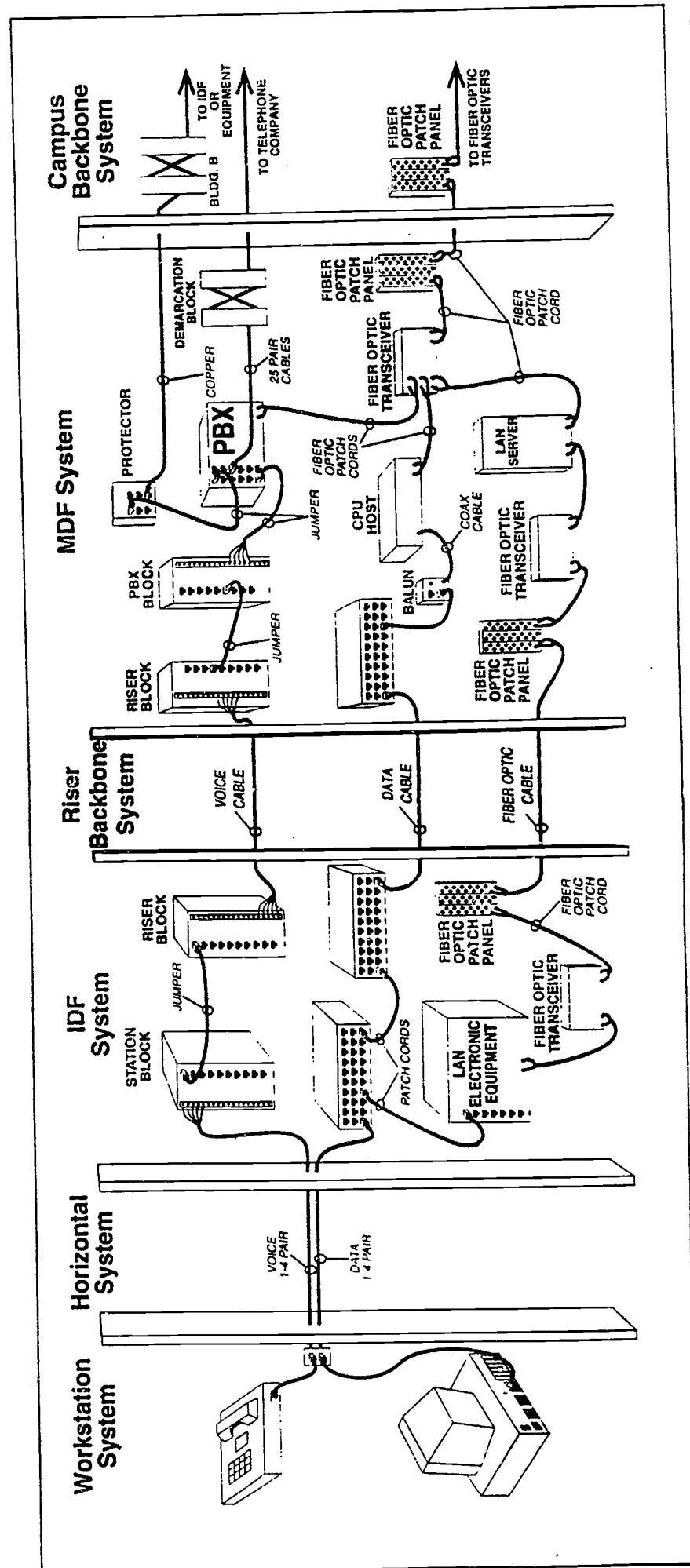

Figure 6.

Physical Topology

Physical topology is the way the network nodes and stations are connected. The four basic physical topologies are STAR, RING, BUS, and POINT-TO-POINT.

The data-communications network architecture segments includes:

- The Front-end: The segment of the system that extends from the workstation to the telecommunications room.
- The Backbone: The segment between the telecommunication room and computer center.
- The Back-end: Interconnects major computer-system components, such as data center wiring linking hosts and peripheral equipment.

5.16 System Configuration

Building a cabling system's configuration, the designer should:

- Determine what type of services are needed and,
- Where they are to be located.

A voice, data, and video station requirements schedule will help accomplish this task. The "Telecommunications Systems Configuration Schedule" indicates room number, room description, quantity and type of each device, and the point of termination. A great consideration should be given to future needs and system expansion.

TELECOMMUNICATION SYSTEM CONFIGURATION SCHEDULE									
Room No.	Room Name	Station							
		Voice		Data		Video		Wire Closet	Remarks
		Quan.	Type	Quan.	Type	Quan	Type		

5.17 Face-Plate Configuration

The face plate configuration for a service device (outlet) depends on the nature and type of service delivered. A multiport device plate should be provided if more than one type of service is needed at one location.

5.18 Space Requirements

To determine space requirements for a communications system, the designer should establish the following:

- Station requirements.
- Zoning (for the system).
- Distance constraints.
- Capacities.

Centrally located telecommunications rooms can serve approximately 60,000 square feet of floor space for overhead distribution systems or 30,000 square feet for in-floor distribution systems. When rooms are located in a building perimeter, they serve approximately 30,000 square feet for both overhead and in-floor distribution systems. Rooms should be located within 250 to 300 feet of the farthest workstation. Each room should be: (see Fig. 7).

- At least 80 square feet.

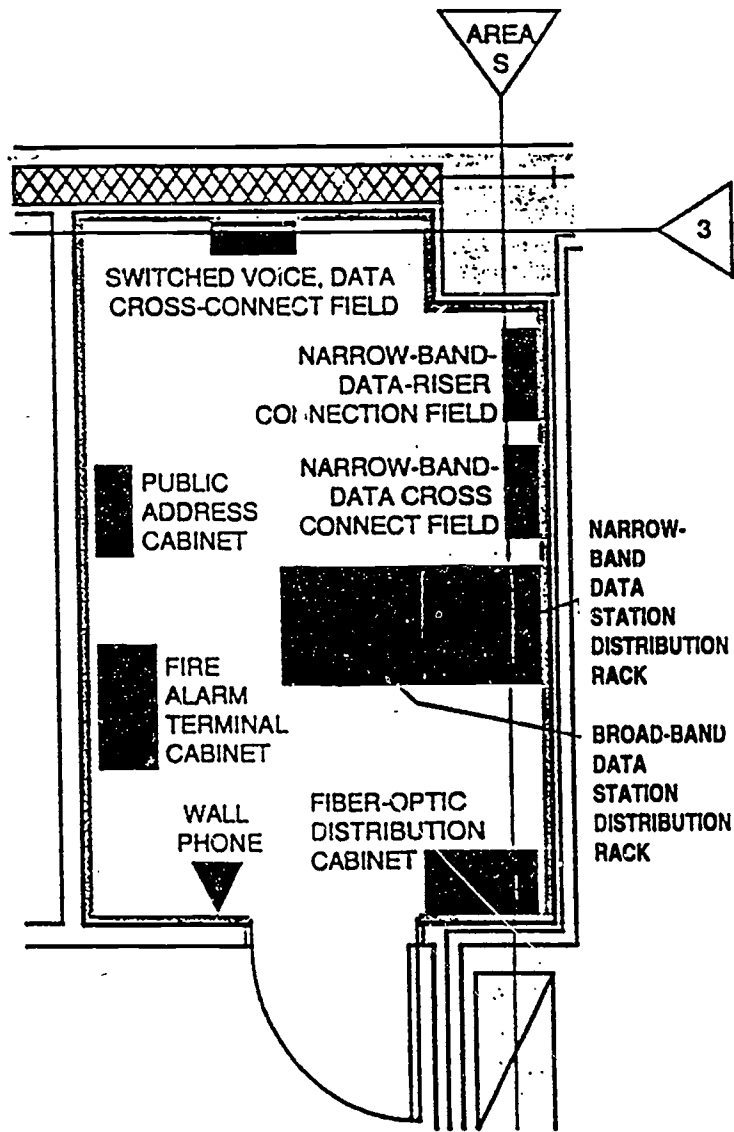
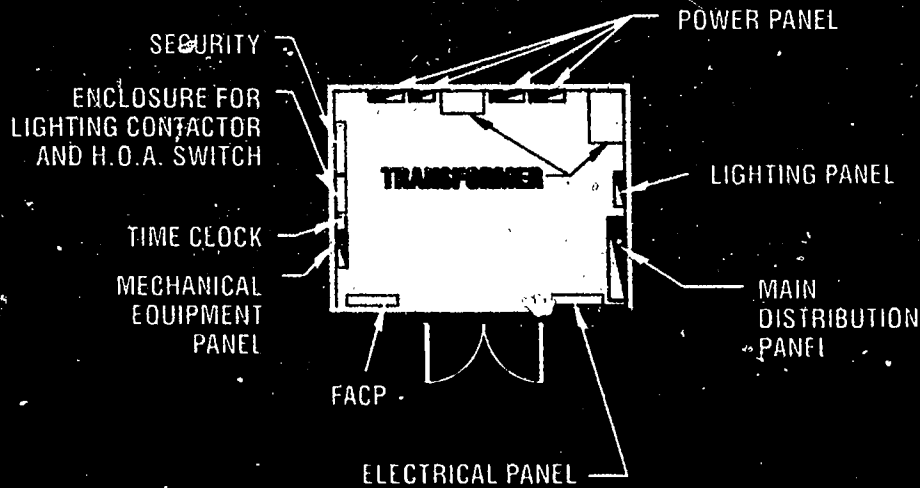
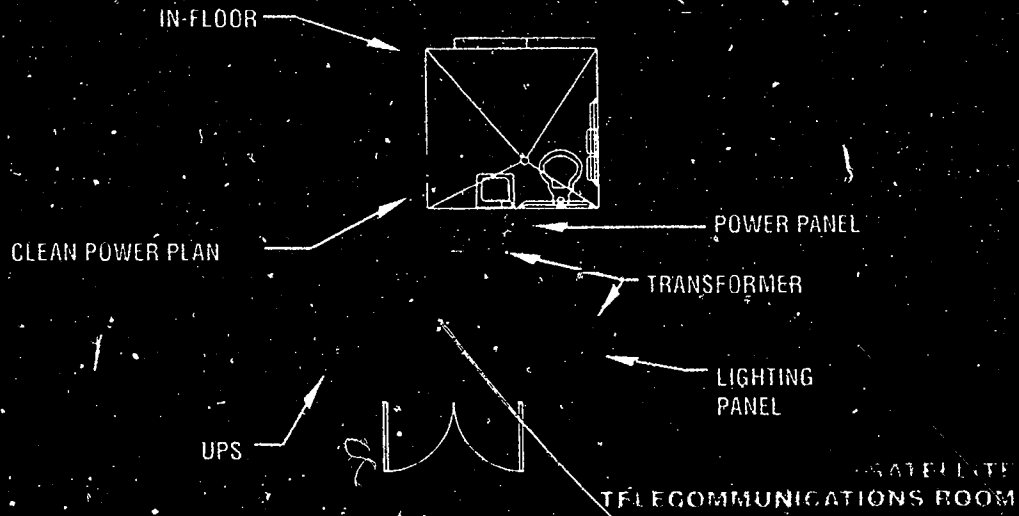
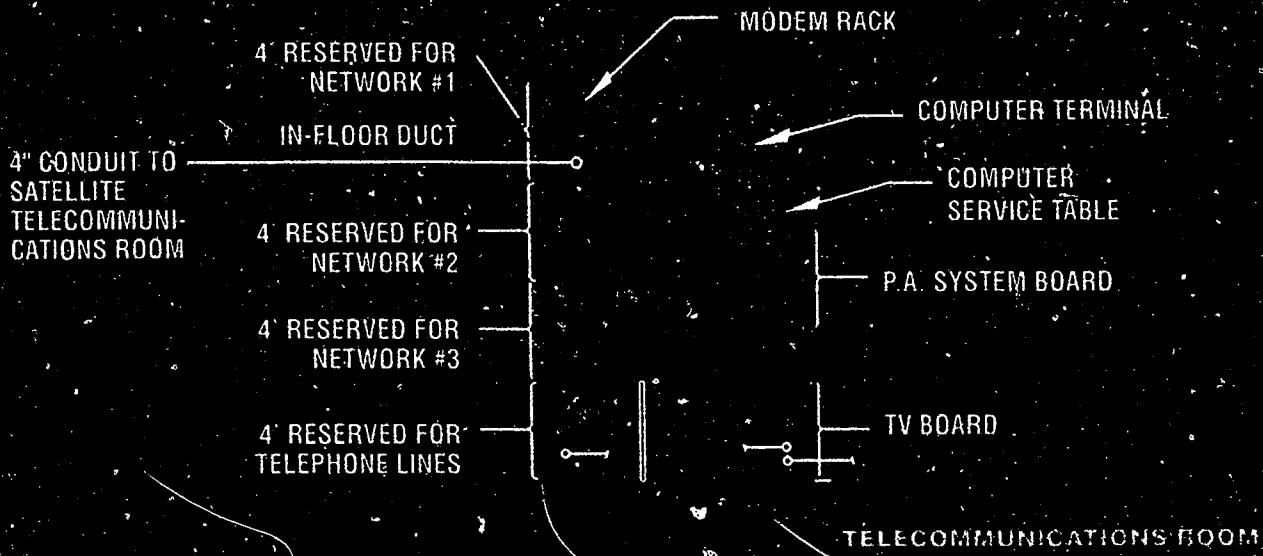

Figure 7.

The Harold G. Zopp Memorial Library

Spring Hill, Florida



- Walls should be lined with 3/4 inch fire treated plywood six inches above the floor.
- Doors should swing out.
- Environmentally controlled.
- At least one duplex power outlet on each wall.

5.19 System Infrastructure

The infrastructure to support a Structured Cabling Systems (SCS) includes overhead distribution system and in-floor distribution system (under floor distribution). Cable trays, wireways, and conduits can be used for overhead distribution systems. Under floor duct system, under floor cellular system, trench duct, and conduit can be used in in-floor distribution systems.

Today's buildings are changing every year. Becoming more automated, more complex in their needs. Providing a distribution system for electrical power and telephone service is no longer enough, because tomorrow's buildings will need distribution channels for a sophisticated network of electronic systems, data processing and transmission, automated security systems, and energy management systems. Preparing a building for the Future making it an "intelligent" building.

The system infrastructure should:

- Have capacity for the life of the building to handle ever increasing cabling requirement;
- Be flexible to adapt to building interior changes and increased number of work stations;
- Let your building meet its future needs without expensive modifications;
- Be able to accommodate all major communications and data systems connector devices.

5.20 In-Floor Distribution System

5.20.1 Under-Floor Duct System

3 Compartments - \$15.00 per L.F.

- DATA Compartment
- POWER Compartment
- VOICE Compartment

Each service box will cost from \$100 to \$400 depending on the quantity and type of devices in the box.

5.20.2 Recessed Floor Boxes

These boxes are available in:

- Universal box which contains power, data, and voice devices
- Single box for each of the services (power, data, and voice) needed.

The above boxes utilize conduit distribution grid system.

Poke-Through Floor Box - \$80.00 per box

- Single box for each of the services needed.
- Used primarily in multistory buildings where the floor box is fed from the floor below.

Raceway (conduit) System

- This system is used primarily for low budget projects. It involves connecting strategic and important areas of the building to the main telecommunication and power rooms. See Table "Cost Per Linear Foot (installed)"

TABLE: COST PER LINEAR FOOT (INSTALLED)		
Conduit Size	PVC	IMC
3/4"	\$1.20	\$1.50
1"	\$1.50	\$1.80
2"	\$2.40	\$2.60
4"	\$5.60	\$7.80

5.21 Overhead Distribution System

- Cable Trays
- Wireways
- Conduits

5.22 Surface Mounted Raceways

- Used for above counters
- Used in renovation projects
- Three Compartment Raceway
 - Power Steel: N\A
Plastic: \$3.25/L.F.
 - Data
 - Voice
- Two Compartment Raceway Steel: \$4.50/L.F.
 - Power Plastic: \$1.50/L.F.
 - Telecommunications
- Single Compartment Steel: \$3.00/L.F.
 - Plastic: \$1.20/L.F.
- Multi-outlet System (Plug Mold) Steel: \$1.50/L.F.



5.23 The Do's and Don'ts of Cabling and Raceways

- DO - Buy the best UTP you can afford.
- DO - Buy termination equipment (RJ45's, punch blocks, etc.) that meet or exceed the quality of your cables.
- DO - Label cable ends.
- DO NOT - Mix up RJ45's designed to work with standard UTP with those designed for solid UTP.
- DO - Maintain the wire twist for all pairs up to the point of termination.
- DO NOT - Share voice and data application in the same cable.
- DO - Terminate voice and data cables into different punch blocks or racks.
- DO - Use minimum bend radius of TEN times the cable diameter.
- DO - Allow for sufficient cooling air flow in the telecommunications room.
- DO - Put a lock on the wiring closet door and use it.
- DO - On multi-floor installation, locate satellite telecommunications closets where there is a common vertical access (shaft).
- DO - Install sufficient power outlets.
- DO - Avoid routing cables near EMI noise sources, such as motors and AC power lines.
- DO - Use the same cable throughout. Don't mix up cable from different manufacturers.
- DO - Insist the installation be tested with equipment that meets or exceeds the requirements for the installation, and get a certification report for each cable.
- DO - Provide the telecommunications room with the following:

- Sufficient depth to accommodate data shelves or racks; minimum of 24 inches for a cabinet with full width doors, or a depth of 48 inches for walk in cabinets.
 - Ground lug or ground bar with a minimum #6 AWG wire to an approved ground.
 - Sufficient 110V AC power outlets for initial and future electronic equipments. Outlets should be on dedicated circuits.
 - Sufficient HVAC air flow to prevent overheating of equipment in the Room.
 - Space for UPS or power conditioning equipment if required.
- DO - Identify all potential sources of interference and route the cables away from them. Maintain a distance between the interference and the UTP of 10 times the diameter of a medium VOLTAGE AC power cable and 100 times the diameter of a high VOLTAGE AC power cables.
 - DO - Whenever possible cabling should be installed over corridor areas or along lines that are parallel to the contours of the buildings.
 - DO- Cabling installed above suspended ceilings should be supported either in a cable tray or cable hangers spaced 12 to 24 inches apart.

SUMMARY

CONDUIT ...

ITS IMPORTANT PLACE IN THE WORLD*

- It's cheap to purchase, it takes very little labor to install during construction. *You'll pay more for it later, and labor to install it will be a killer.*
- It takes very little time to install during construction. *You won't believe the disruption caused when you have to install it once you have moved in.*
- Extra conduit is like money in the bank. *It gives you comfort that it's there and it lets you preserve all your options for later.*
- We never met a librarian who complained about having too much conduit. *On the other hand there is long list of those who don't have enough and remain frustrated forever.*
- We all know blood vessels and arteries are the essential two-way circulation system of the body which it cannot live without. *Conduit serves the same essential function in a contemporary library, it can't operate without it.*
- They say one can never be too rich or too thin. *We say one can never have too much conduit.*
- When in doubt about whether you need extra conduit between areas of the library, don't belabor the decision, just have it installed.
- In short, conduit is wonderful to have and miserable to be without. *Plan your life accordingly.*

* Conduit can also refer to floor duct systems and cable trays.

FLEXIBILITY ENHANCEMENTS - DATA GRID

ROUTING RECOMMENDATIONS

(Redundancy Is Important)

Hub Location	Hub Connects to Space Below	
Telecommunication Room	Circulation Desk	
"	Reference Desk	
"	Exterior	
"	Roof	
"	Staff Work Area	
"	Librarian's Office	
"	Community Room	
"	Children's Area	
"	Reading Area	
Circulation Desk	Staff Work Area	
"	Library Office	
"	Reference Desk	
"	Children's Area	
"	Study Rooms	
"	Community Room	
"	Reading Area	
Reference Desk	Reading Area	
"	Staff Work Area	
"	Community Room	
"	Library Office	
"	Children's Area	
"	Study Rooms	

RELATED VOCABULARY

1. **Amphenol-type** - 50 pin connectors (25 pairs) typically used in the past for telephone set connections to central Pbx or phone company based switching. Some times referred to as Telco-Type connectors or DB-50.
2. **As-Built Plan** - An As-Built Plan is the final drawing that indicates exactly where walls, structural systems, conduits and other critical items were installed once the building was built. These plans have very important information that reflects changes that were made during the construction process from the original design documents. Once in hand, these should be carefully guarded and made available to anyone doing renovation or service work on the facility.
3. **Asynchronous** - A communications term that defines a data transmission mode in which individual bytes (characters) are transmitted, one byte at a time, along with individual start/stop bits.
4. **Attenuation** - Deterioration of the strength of signals as they pass through a transmission medium (e.g., through cables, outlets, connectors, patch panels, etc.)
5. **Backbone** - A term that refers to certain cabling segments used to provide connectivity over long distances within buildings as well as between buildings in a campus. It also refer to certain network architecture used to connect multiple subnetworks to one another.
6. **Bandwidth** - A measure of the carrying capacity of a communications device or medium, usually expressed in kilohertz (kHz) or megahertz (MHz).
7. **Baseband** - A term that refers to a band of frequencies and related equipment used to carry signals in an unmedullated form (e.g., in their original electrical form, without modification).
8. **Cable Tray** - A long continuous rack usually located above a ceiling, that organizes and supports loose wires or cables. Cable trays are expensive and used primarily in very large complexes. Cable trays usually start at a telephone or computer room and branch out. Cable trays are the most expensive means of organizing and supporting large groups of wires or cables.
9. **Ceiling Plenum System** - This refers to the area between the ceiling and the underside of the structure. For a ceiling plenum to be used effectively, it must allow easy access and the ability for cables and wires to move in all directions simultaneously. The ceiling plenum can

get cluttered and cumbersome to use later on but is one of the cheapest ways to provide universal distribution of data.

10. **Chases** - These are connecting spaces between floors and buildings, usually rectangular in shape, that allow passage between floors of wires, pipes, conduit and other building services. While most chases are vertical, some can be horizontal in specialized situations. Chase sizes can be as small as 6" x 12".
11. **CMP** - A designation established by the NFPA that refer to Plenum-Rated Cables.
12. **Coaxial** - A type of cable consisting of one central wire surrounded by a dielectric insulator and encased in either wire or metal sheathing.
13. **Coaxial Cable** - This is another type of data communication cable. It is identical in many ways to your home television cable. It has an exterior metal shield, a plastic core and a single conductor in the center. Certain data systems require use of a coaxial cable.
14. **Conduit** - Usually a specialized plastic or metal pipe of varying size that can individually carry wires, cables or fiber optic bundles throughout a building. Conduits are cheap and can be routed in any horizontal or vertical direction.
15. **Cross Talk** - The unwanted transfer of signals form one conductor another.

16. **Data Grid** - This is a distribution system that connects the various hubs of the library with each other and also provides data sources and interaction capabilities to individual locations. The grid can be either under floor or overhead or may in some cases be a mixture of both systems. The grid material itself can be either conduit, floor duct or cable trays. Most data grids use conduit. Basic elements of a data grid:
- **Junction Boxes** - Located at each access point to the grid.
 - **Distribution System** - The conduit, floor duct or cable trays that contain the conductors. All distribution systems have main trunks, some have secondary trunks.
 - **Main Trunk** - The primary element of the distribution system that connects hubs.
 - **Secondary Trunks** - The branch elements of this system that connect the hubs to individual users or terminals.
 - **Hubs** - These are key distribution points in the grid. Hubs are connected to the telecommunications room and to each other. They are usually located in a large in-floor junction box that is easy to access.
17. **Dedicated Power Source** - This refers to individual circuits within the library's electrical system that are isolated from other power consuming equipment. Dedicated Power Sources are usually established for computers and their output systems in order to help ensure that this sensitive equipment will have its own power and will not be corrupted by fluctuations in usage from other systems within the library.
18. **Earth** - British term for zero-reference.
19. **Electrical Ground\Electrode** - Cable or metal system that provides connection between the ground wire of an electrical device to the earth for the purpose of establishing an electrical ground.
20. **EMF (Electro Magnetic Field)** - An EMF condition is usually a negative impact that has the potential to result in disruption and harm to magnetic media that contains numerical, video or audio data. There are very few studies that provide concrete proof as to when an EMF condition is excessive. The best advice is to avoid areas that could be a contributor. EMF's are usually found adjacent to high-power overhead transmission lines or very large transformers. Local utility authorities should always be contacted whenever there is suspicion regarding negative EMF conditions.
21. **Encapsulating** - A pourable, fast setting compound used to seal splice on cables.

22. **Ethernet**- The local area network technology developed by Xerox, Intel and DEC in late 70's to support 10 Mbps transmission speed.
23. **Excess Loss** - In fiber optic coupler, the optical loss from that portion of light that does not emerge from the nominally operational parts of the device.
24. **Extrinsic Loss** - In a fiber interconnection, that portion of loss that is NOT intrinsic to the fiber, but is related to imperfect joining which may be caused by the connector of the device.
25. **FDDI**- An acronym that stands for Fiber Distribution Data Interference, an ANSI standard for fiber based Token Ring physical and data link protocol.
26. **FDM** - An acronym that stands for Frequency Division Multi-plexing, a technique for combining many signals on one circuit by separating them in frequency.
27. **Fiber**- Thin filament of glass or plastic comprised of a core and a cladding which is capable of carrying information in the form of light.
28. **Fiber Optics** - This data conductor utilizes thin strands of glass fiber instead of metallic conductors. Fiber optic conductors are made of bundles containing hundreds of individual strands. This is the most expensive system available for a data conductor. It offers the optimum in data through-put and capacity. Attachment devices at each end of the fiber optic cable are also very expensive and should be priced as part of the total analysis.
29. **Fire Stopping** - The use of special materials to prevent the outbreak of fire within telecommunications spaces to block and prevent the spread of fire and smoke through openings in floors and walls.
30. **Floor Duct** - This is a variation of an under floor data grid system. A floor duct is a rectangular opening placed slightly below the floor with a layout that is usually in a grid fashion and allows the installation and access of loose wires or cables.
31. **Full Duplex** - Is the opposite of a half duplex, the ability to communicate in both direction or send and receive over the same circuit.
32. **Fusion Splicing** - A permanent joint accomplished by the application of localized heat sufficient to fuse or melt the ends of two fibers to form a continuous signal fiber.
33. **Gain** - Increased signal power, usually the result of amplification.

34. **Gas Pressurization** - A method of preventing water from entering small cracks in cable splices or sheath and or alerting personnel to larger leaks by keeping air core cables under pressure with dry gas.
35. **Gauge** - A term used to denote the physical size or diameter of a wire.
36. **GIG** - Prefix meaning billion.
37. **Gigahertz** - A unit of frequency equal to one billion hertz.
38. **Ground Conductor** - A conductor in a transmission cable or line that is grounded.
39. **Ground Start** - A signaling method where one station detects that a circuit is grounded at the other end.
40. **Grounding Terminal Rod** - A grounding terminal is an essential part of any telecommunications and data system. It provides an important means of isolating the electrical system from spurious electrical changes. The better the ground the higher quality your data will be.
41. **Half Duplex** - A telecommunications circuit that transmits or receives at one time.
42. **Hard-Sheath Cable** - Cable or wire contained within a continuous inner or outer metallic sheath.
43. **Hard-Wired** - Wire and cable that is in place or installed for one designated purpose.
44. **Hardening** - Shielding and protecting of plant and equipment circuitry from the effects of radiation and transient electromagnetic pulse (EMP) which accompany a nuclear explosion.
45. **Harmonic Distortion** - Interference resulting from some type of harmonic signal measured in decibels (dB).
46. **Harmonic Frequency** - A frequency that appears as a result of a strong signal at a lower frequency.
47. **Head-In** - The main or top transmitting device in a Broadband network where all transmissions are distributed.

48. **Header Duct** - The main or feeder duct for bringing cable from satellite/riser closets or distribution ducts in cellular and under floor duct system.
49. **Henry (H)** - The standard unit of inductance. The inductance of a current is one HENRY when a current variation of one ampere per second induces one volt.
50. **Hertz (Hz)** - Standard unit of frequency, equal to one cycle per second.
51. **Horizontal Wiring** - The part of the wiring distribution system that extends station cabling from Intermediate Distribution Frame (IDF) to the workstation/telephone outlet.
52. **Hybrid Cable** - A cable used for communications which contains a minimum of two or more conductors that carry electrical signals.
53. **ICEA** - Insulated Cable Engineers Association.
54. **IEEE** - Institute of Electrical and Electronic Engineers
55. **IDC** - Insulated Displacement Connection, The type of wire terminal that requires no wire stripping.
56. **Impedance**- The total opposition that a circuit offers to the flow of alternating current at a particular frequency. It is a combination of resistance (R) and reactance (X) and is measured in ohm.
57. **Inductance**- The property of a circuit that opposes any change in existing current during a period of a change.
58. **Infrared Emitter** - This term is usually associated with an assisted hearing infrared broadcasting system. An emitter is usually unobtrusive and can be mounted on a wall or ceiling. Individual receiving devices pick up the radiated signal which is invisible to the eye. Emitters do not have to be in a line of sight for an infrared receiver to receive a clear signal. However, emitters can be in conflict with other light sources primarily those from the outside. Studies should always be done prior to making a commitment on an infrared system, especially where the library will have large windows that are open to direct sunlight.
59. **Insulation** - A material having good dielectric properties which is used to separate close electrical components, such as cables.

60. **IDF** - An acronym that stands for Intermediate Distribution Frame. Also commonly referred to as a wiring closet or telephone closet.
61. **I/O** - Input/Output.
62. **Junction Box** - The junction box is an essential component of any data grid and provides a beginning and end connector for conduit and under floor systems. Junction Boxes have covers to protect the grid. Thus provide the best location to access the data grid.
63. **Mounting Board** - This is a fastening surface located in the telecommunications room usually of plywood that allows the installation of various types of equipment and consoles related to telephone and telecommunications systems. A good mounting board is easily accessible and is well lighted in order to facilitate efficient and effective services. The larger the mounting board and the more spare room it has available the better.
64. **Multimode** - Refers to a class of fiber optic cabling that is compatible with most applications of fiber.
65. **NEXT** - An acronym that stands for NEAR-END CROSS TALK. It refers to crosstalk measurements between conductors media (pairs) in the near or transmitting end of signalling equipment, as opposed to measurements taken between conductors (pairs) at the receiving end of a circuit.
66. **RG-62** - Designates a classification of coaxial cables, especially those are native to IBM 3270 connectivity scheme.
67. **RJ** - An acronym that stands for Registered Jack.
68. **RJ-11** - Usually refers to an RJ type jack containing from two to six conductors.
69. **RJ-45** - Usually refers to an RJ type jack containing eight conductors.
70. **RJ-232** - Refers to an EIA specification for asynchronous communications that feature a 25-pin connector.
71. **Single Mode** - Refers to a type of fiber optic cabling that contains a very narrow core strand, usually 8 to 10 micron in diameter.

72. **Surge Protector** - Surge Protectors are an essential part of any library's electrical system when computers and sensitive electronic output devices, such as printers, are installed. Surge Protectors stop an unexpected electrical pulse of power from an accidental shorting of the electrical system from damaging the electrical components. They also protect from power grid surges. Surge protection equipment is not very expensive and can be easily included in any renovation or expansion plan.
73. **Telecommunications Room** - This is a room no contemporary library can afford to be without. This room houses the equipment necessary to connect the library's communications systems (voice, data and video) to the outside world. It forms the key distribution point for the data grid. Essential features are:
- It must be large enough for technicians to service its equipment without being cramped (minimum of 50 sq. ft.).
 - Be air conditioned and have extra unused conduit, floor ducts or cable tray space to allow for future installations of data systems.
74. **Token Ring** - A type of baseband LAN usually characterized by 4 or 16 Mbps transmission speeds.
75. **Twisted Pair** - This refers to telecommunications and data transmission conductors. It generally is two- or four-pair wires that run between computers, output devices and other telecommunication systems. Another common term for a twisted pair is a two or four wire telephone line.
76. **Under Floor System** - This refers to a data grid that is located underneath the floor of a room. The installation can be in conduit or it can be in floor ducts. Under floor distribution systems are considered the best data grids since they allow service to individual areas of the library in an unobtrusive manner.
77. **UPS (Uninterruptible Power System)** - An UPS is essential for telecommunications, computing and data grid installations. This system is designed to provide clean power to sensitive electronic equipment. It also provides some temporary power during power outages that occur frequently in some parts of the country. If a total power outage occurs, an UPS may allow 10-15 minutes for sensitive computer equipment to be shut down and working files or data stored before all power is lost. Uninterruptible Power Systems used to be very expensive. Now they are practically priced and should be a common feature of any contemporary library.

78. UTP - An acronym that stands for Unshielded Twisted Pair cabling.
79. Weatherhead or Gooseneck - This is a specialized section of conduit (usually metal) that projects out of a building and is curved like a goose's neck in order to prevent water and bad weather from blowing into the conduit and then coming down into the building. This device is usually found in older facilities where overhead services are connected from power or telephone poles to the building. It occasionally provides a pathway for connections between a satellite dish and the telecommunications room.
80. WECO-Style- WECO is an acronym that stands for Western Electric Company. WECO-Style refers to modular or RJ-type UTP jacks which were originally designed by Western Electric Company.
81. 4-Mbps - A measure of speed meaning 4 million bits per second.